

mushtaq anis

TRANSPORTATION DESIGN

PORTFOLIO

2011

Curriculum vitae



mushtaq anis

Education

2008/11 :Post Graduate Diploma in Transportation and automobile design, National Institute of Design, Ahmedabad, India
2002/07 : Bachelors in Mechanical Engineering, PSG Tech, Coimbatore, India

Experience

2010/11 : 6 months Internship at ONIO Designs, Pune-
Redesign of Indian Icon HM Ambassador
2010 :Vehicle Designer at EVOMO Ltd.
A Low cost vehicle for Rural India
2009 : 3 months Internship at JMC automotive, Chennai
Redesign of Army truck Facia.
2007/08 : 1 year as Design Engineer, (R & D, Fit & Finish), TVS Motor company, Hosur
Worked on the TVS Wego scooter.

Skills

Free hand sketching, Clay modelling, Digital sculpting- 3ds max and Alias Studio tools, Photoshop, Flash and 3d animation

Other Interests:

Formula1, experimental music- exploring and creating, Scale Models collection, Gadgets, animation, exploring cuisines

Contents

_Audi U2_Car for the Indian metro 2015

_Diploma project_BION

_HM Ambassador Redesign

_NID Pininfarina Contest entry

_Interior Motives entry

_Quadrover_rescue hovercraft

_Rebirth

_Sketches

_Renders

_Mercedes coupe

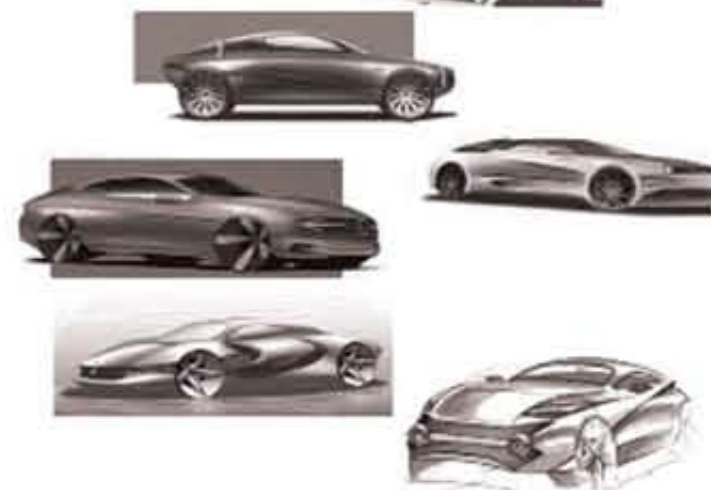



Audi 2015

car for the Indian metro

mini audi
move 2 in luxury

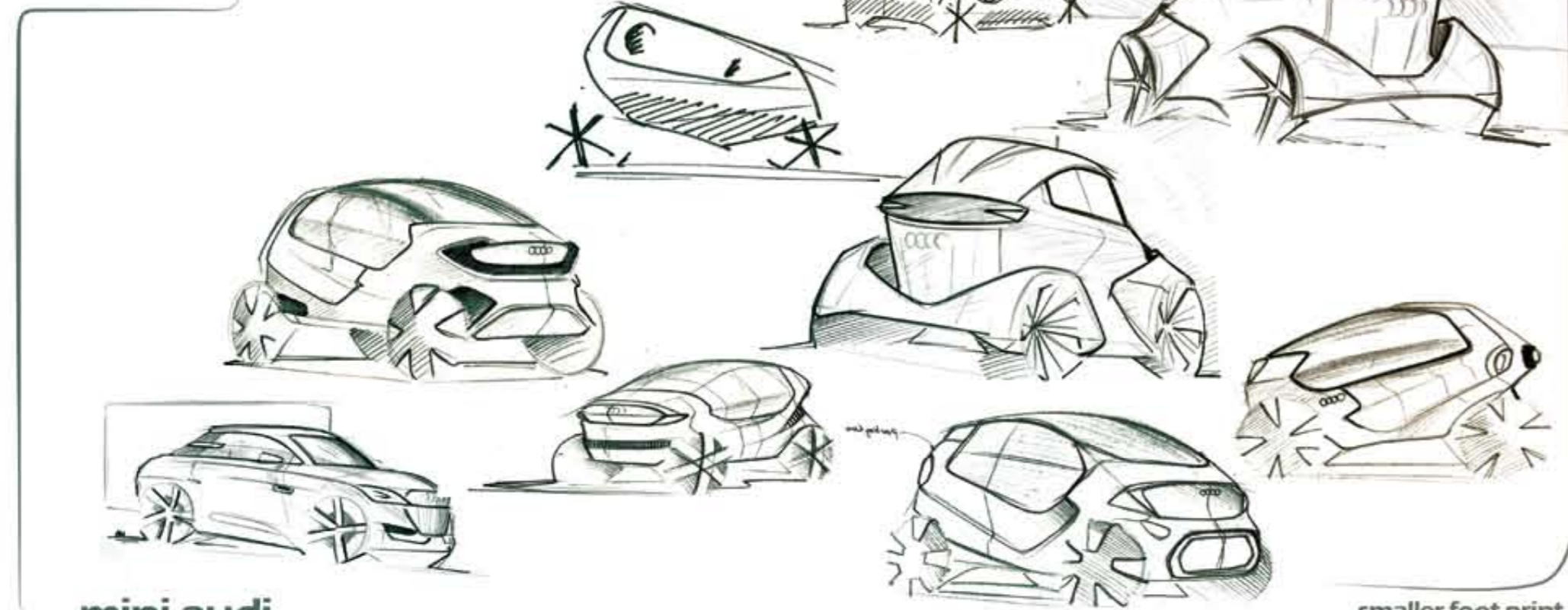

simplicity

smaller foot print

sporty

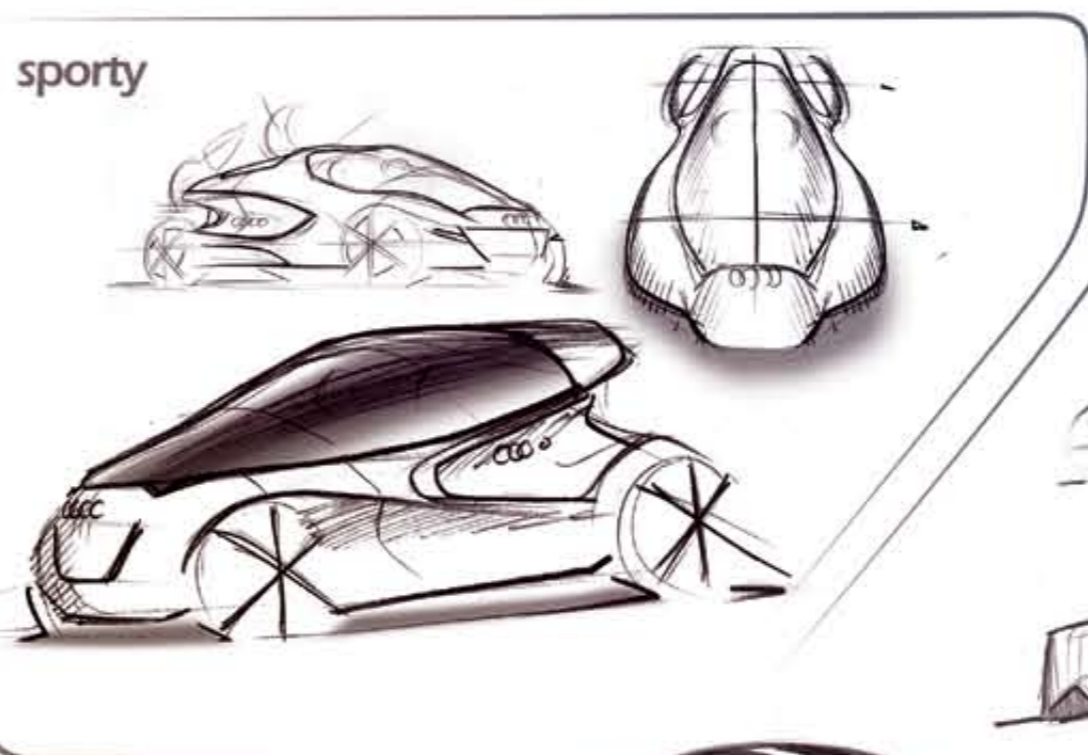

reducing foot print vertically

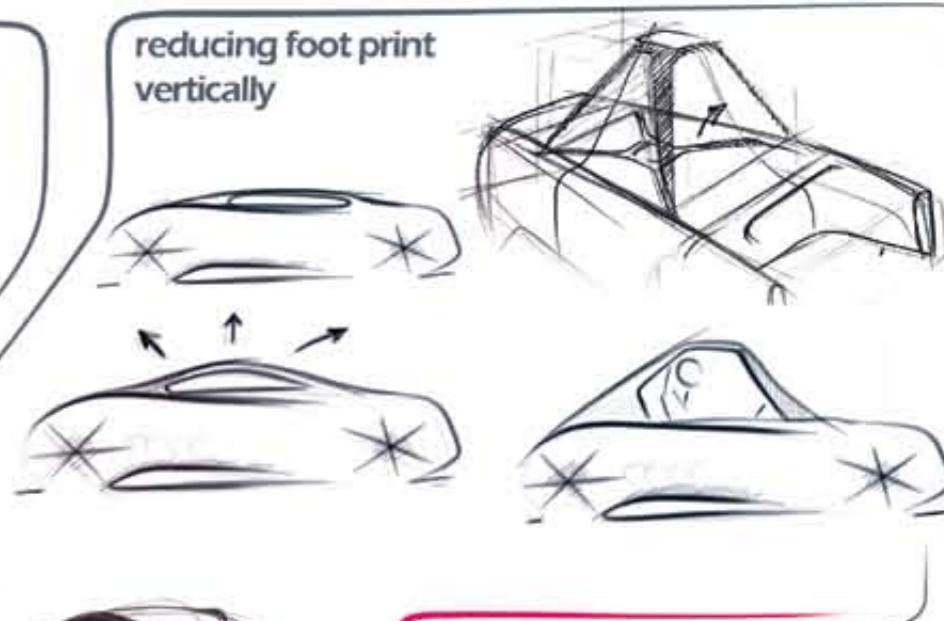

stack parking

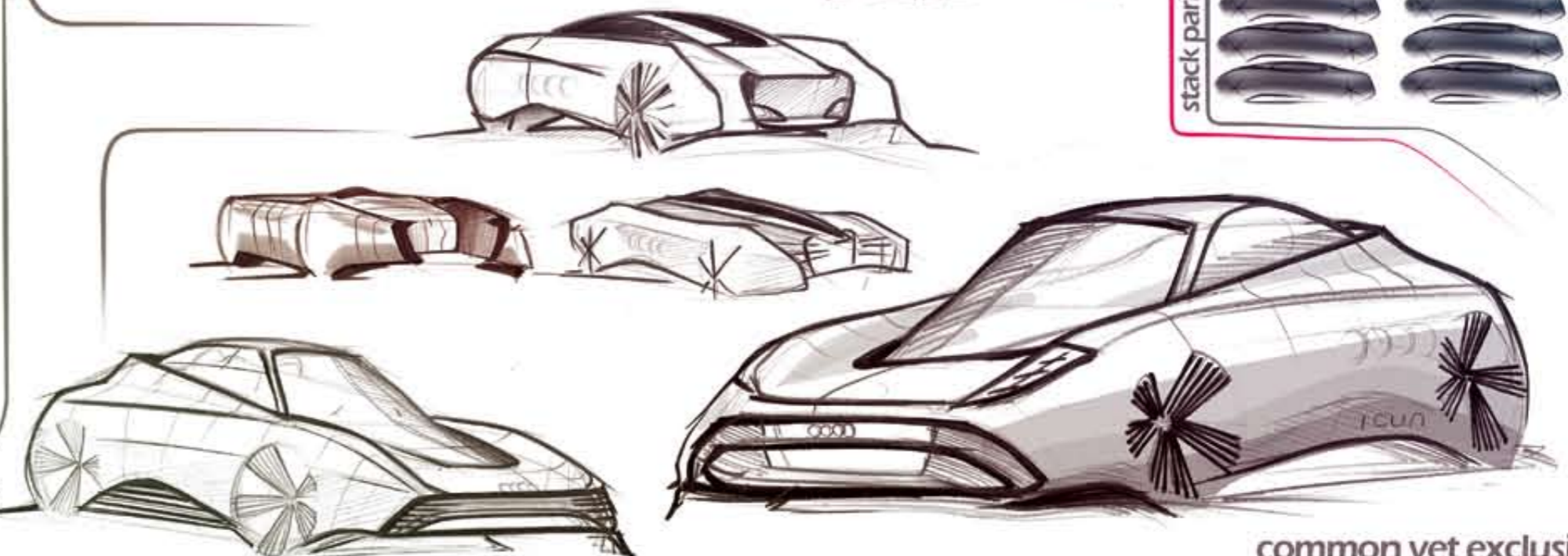

common yet exclusive

Audi for
the Indian metro



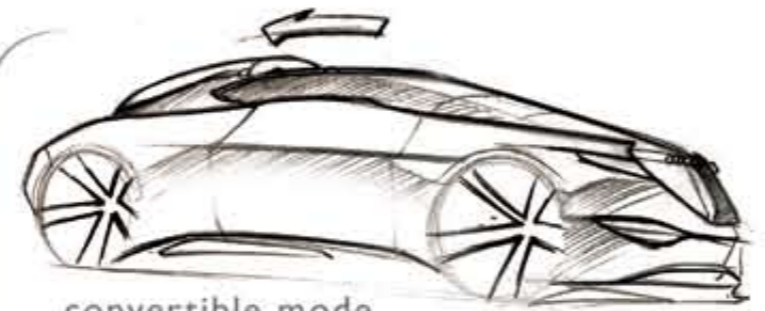
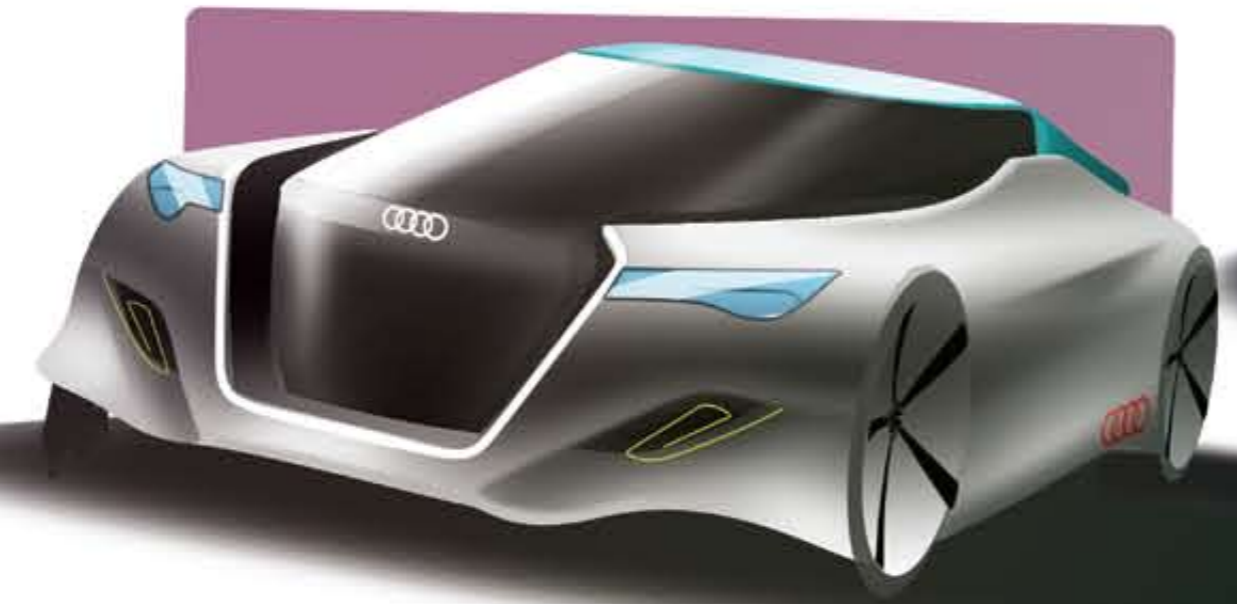

Audi U2
urban luxury

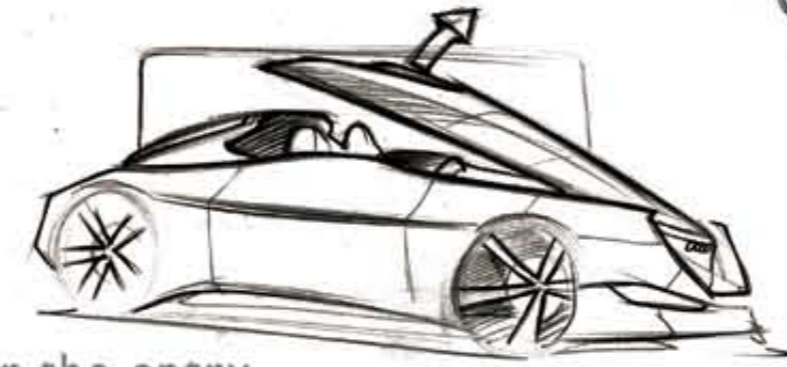

convertible mode

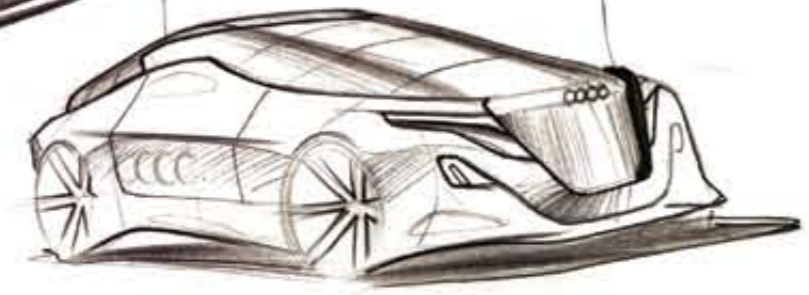
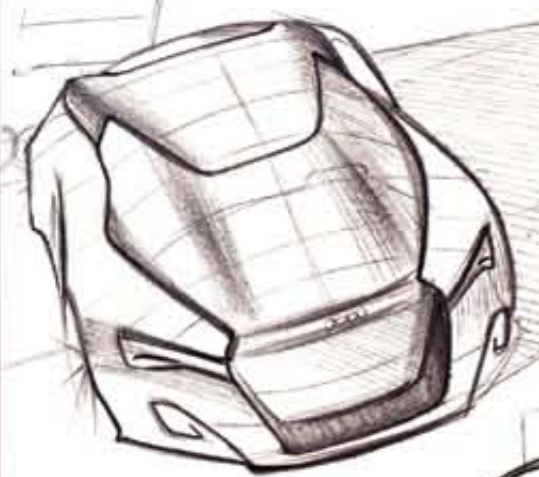

for the entry



Diploma project

car for rural India _VW mobility__BION

India is a country with 70% of its population living in villages. Rural India is under developed because of lack of electricity and mobility. The rural market is a huge untapped market with great potential.

The main occupation is agriculture which gives off a lot of organic waste almost equal to the amount of useful produce. This can be used to produce BIO GAS which is a major fuel source.

A vehicle which people can be used when needed, and when not in use the vehicles are connected to a hub with a BIO GAS unit to generate electricity through solid oxide fuel cells in the vehicle and the current is distributed to the village, so that each village has its own grid and is self sustainable and produces its own electricity. Excess electricity is sold. This will help in development of the villages

VW e-mobility

electrical mobility solution for Rural India



horse/ bullock cart as inspiration for form



simple
friendly
universal
practical

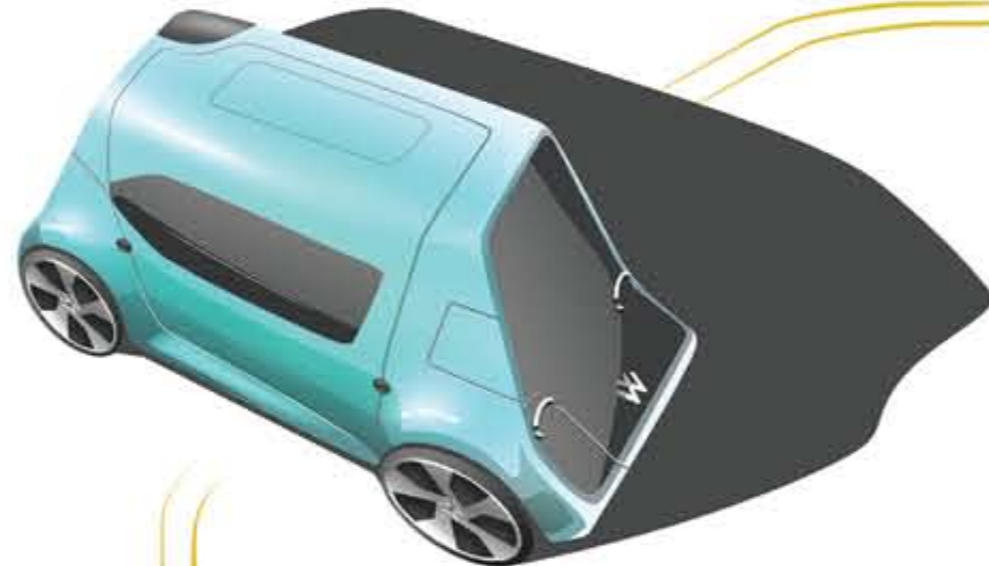

right side



left side

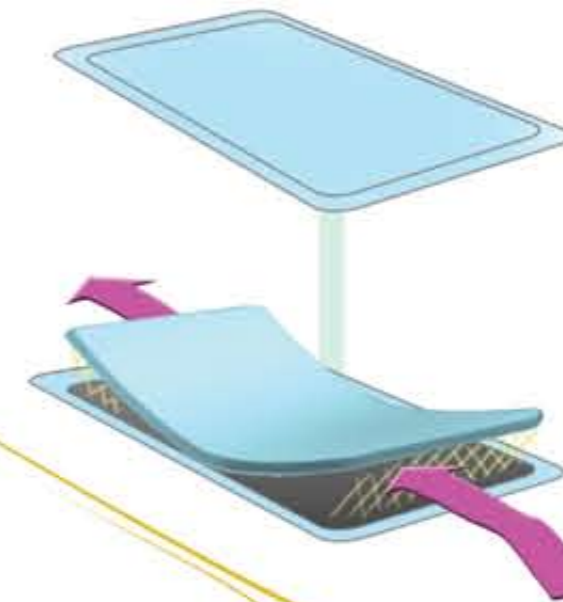

ventilation system

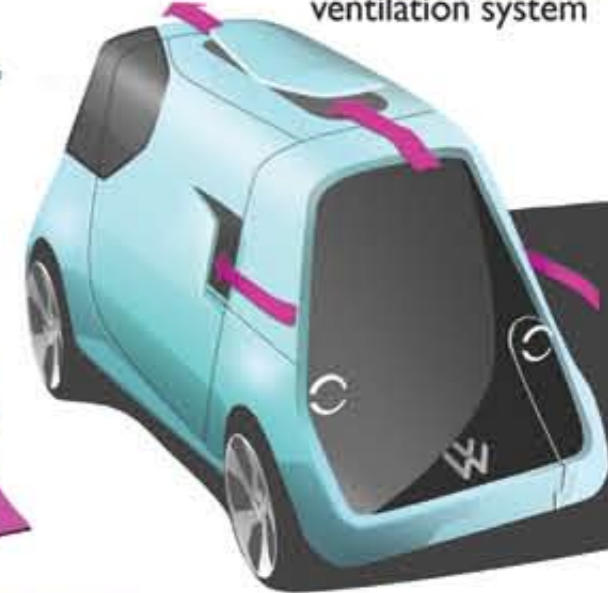

rear

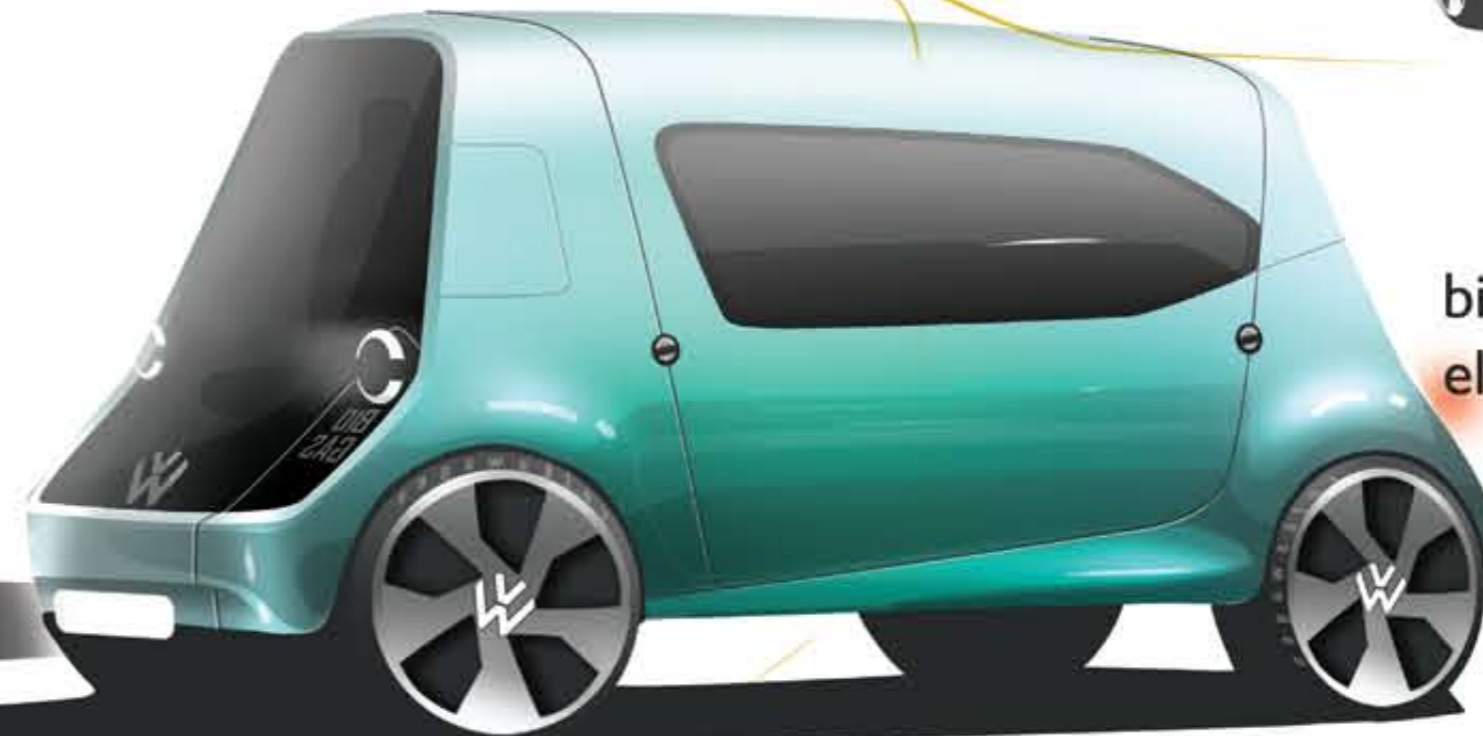

Length - 3200 mm
Width - 1500 mm
Height - 1800 mm

bio gas powered fuel cell
electric car

Rental cum sharing car system.
Users pay only for how much they use

VW e-mobility

electrical mobility solution for Rural India

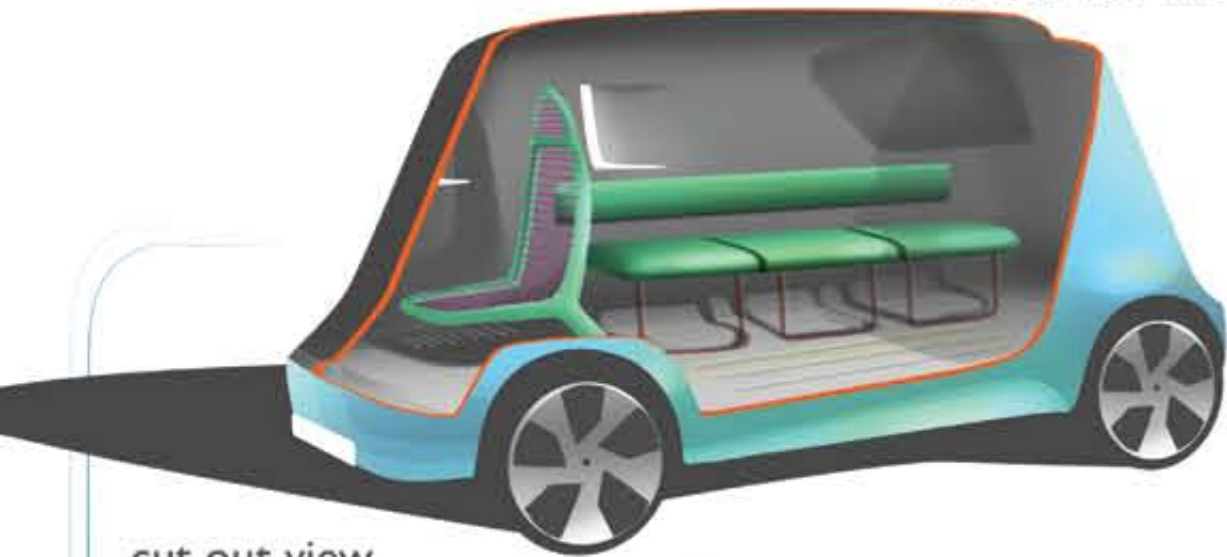

cut out view



driver seat

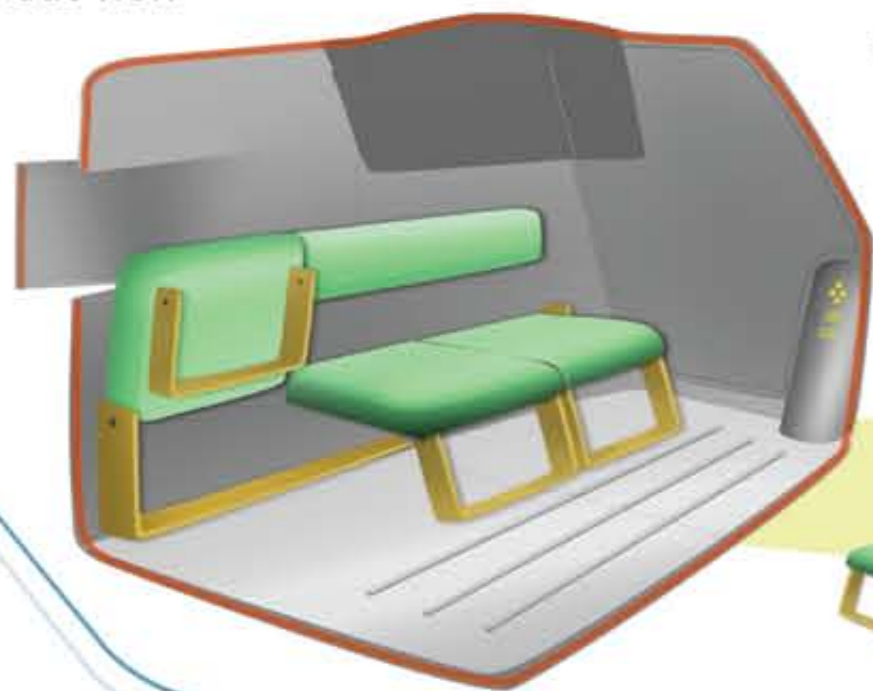

rear seat - foldable / removable benches



assymetrical seating layout

Rental system



the person rents the car when in need

pays the rent and for the electric charge to cover the distance



uses the car to take goods to the market or city

returns to village

the car is taken to the grid and continues producing electricity from bio gas powered fuel cell



scenario

BiONsystem

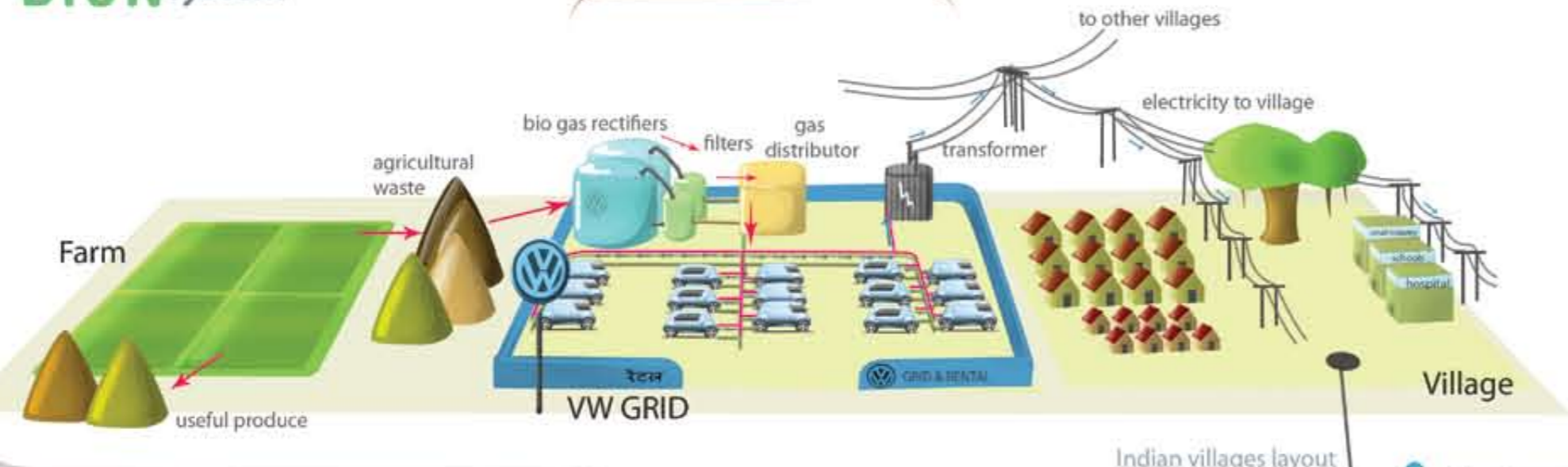

The BIO GAS powered Fuel cell electricity generation system

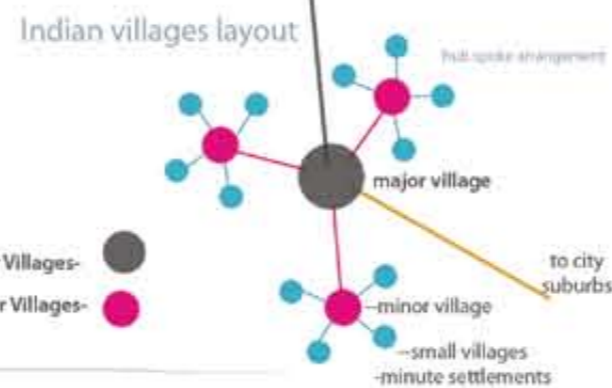

Rural India



- 70 % of India
Huge untapped market
Huge mobility gap

Low income households
Buy everything in small quantities
Pay in small amounts
Cannot afford to own a car

Revenue from this sytem



- From car rentals
- From the electric charge bought for travel
- Sale of electricity to the village
- Sale of excess electricity to nearby villages
- As the village develops , people will start owning the vehicle

taking it ahead

inspiration - The Indian Turban

- the wrapping around of cloth of turban



essential part of a persons clothing

status

pride

custom

prestige

multipurpose

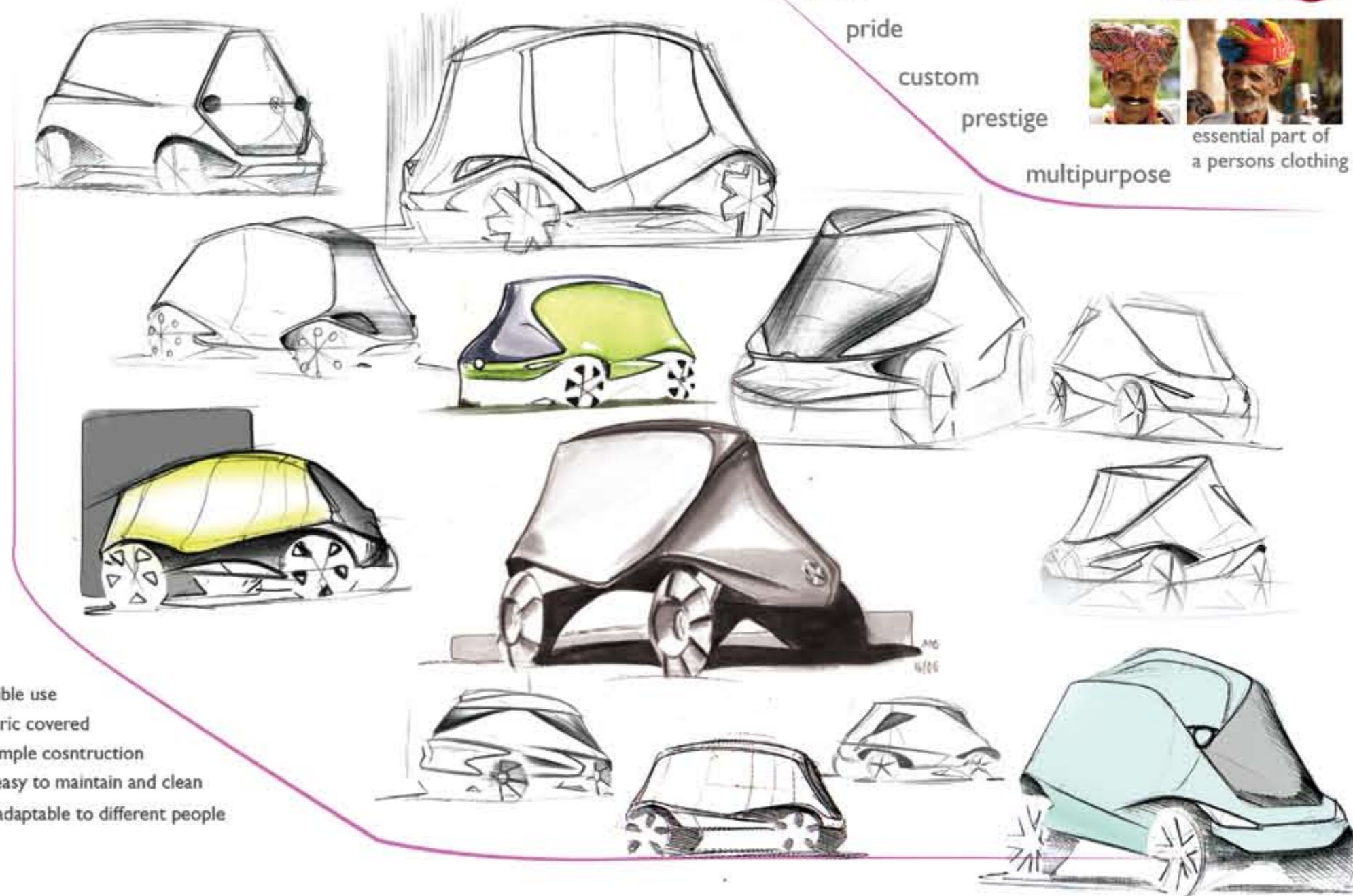

flexible use

fabric covered

simple cosntruction

easy to maintain and clean

adaptable to different people

form refinement and finalising

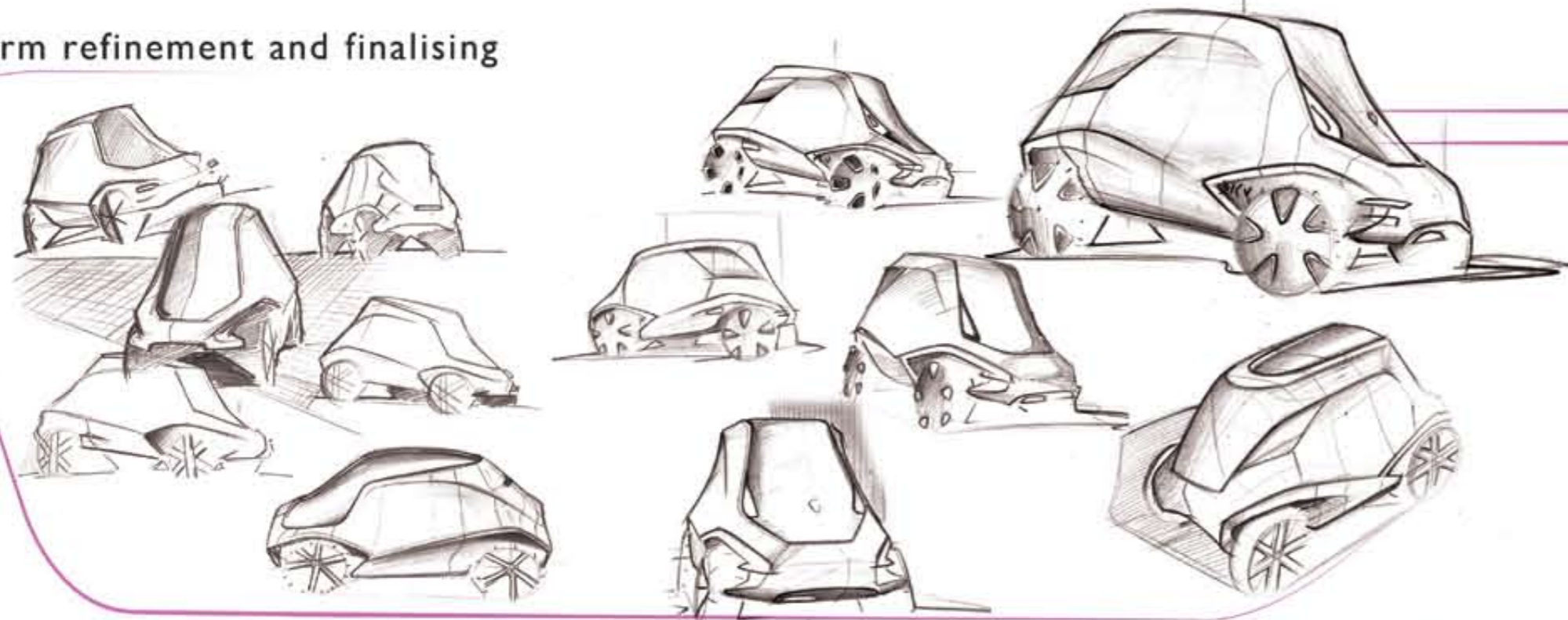

BiON

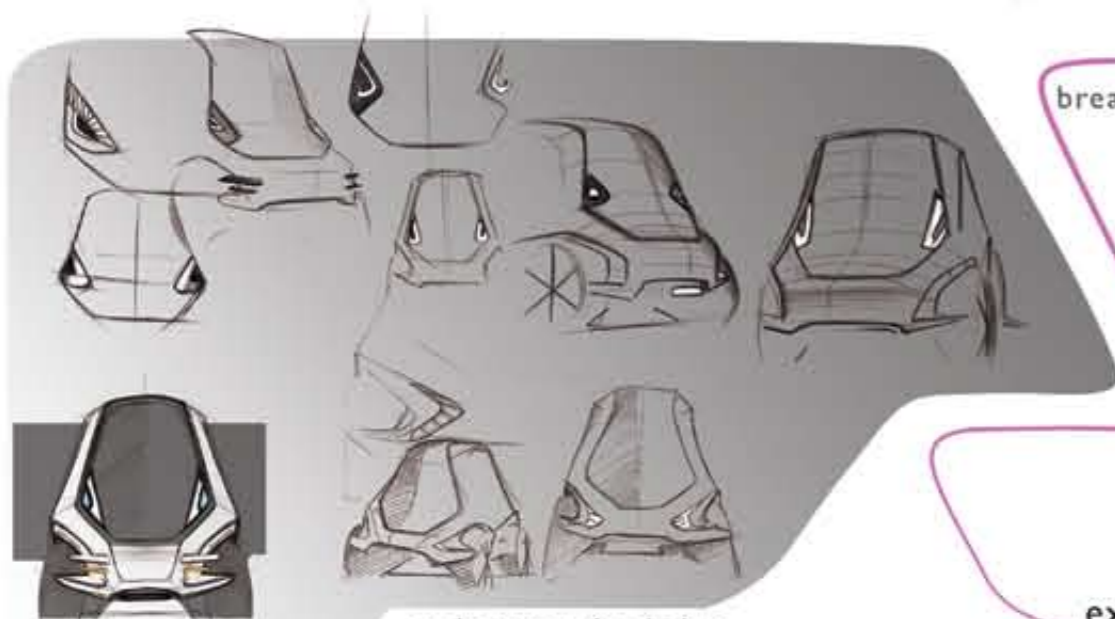
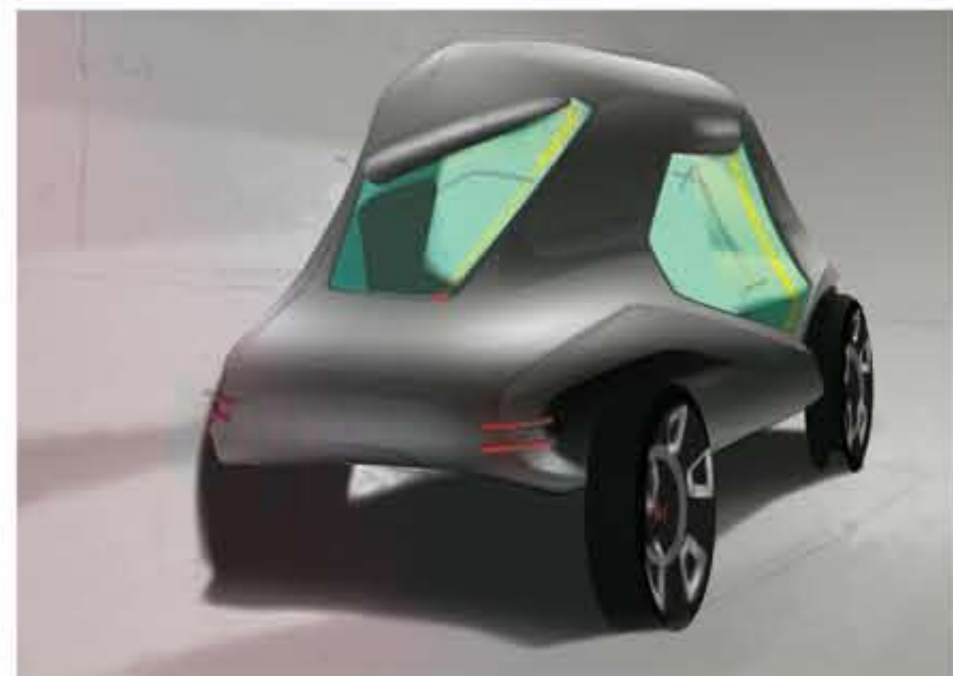
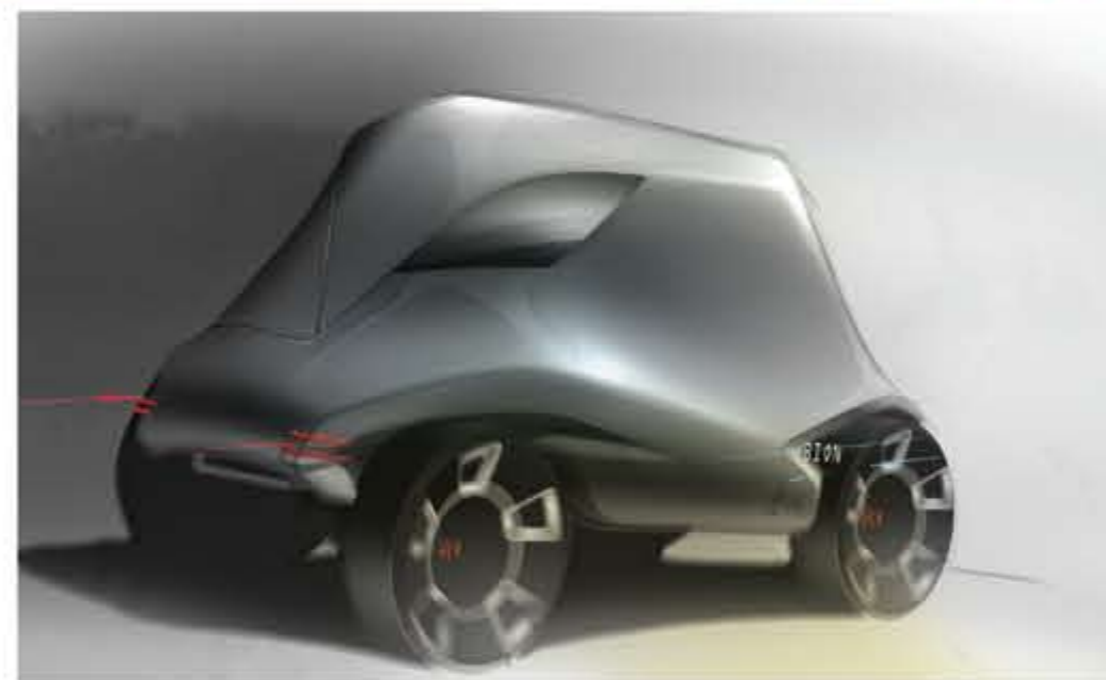

exploration for lights

breaking up the basic 5 spoke

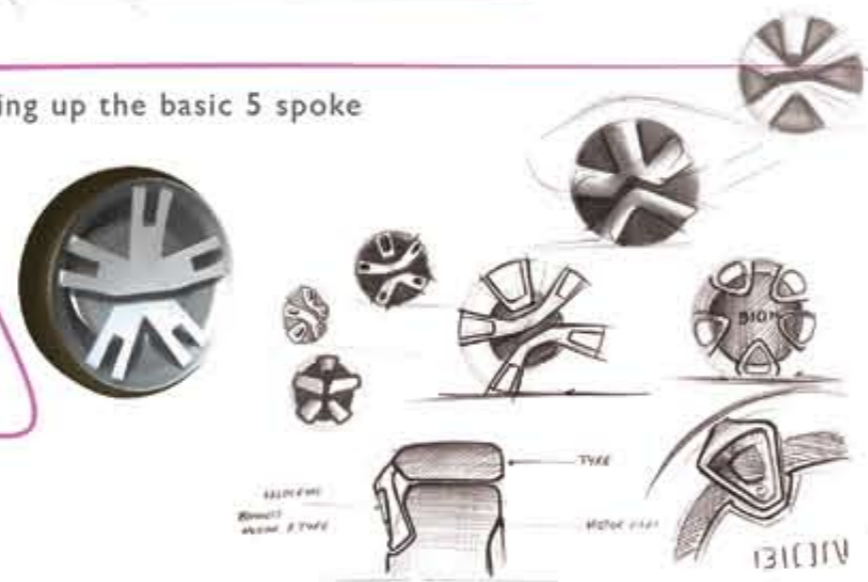

exploration for rims



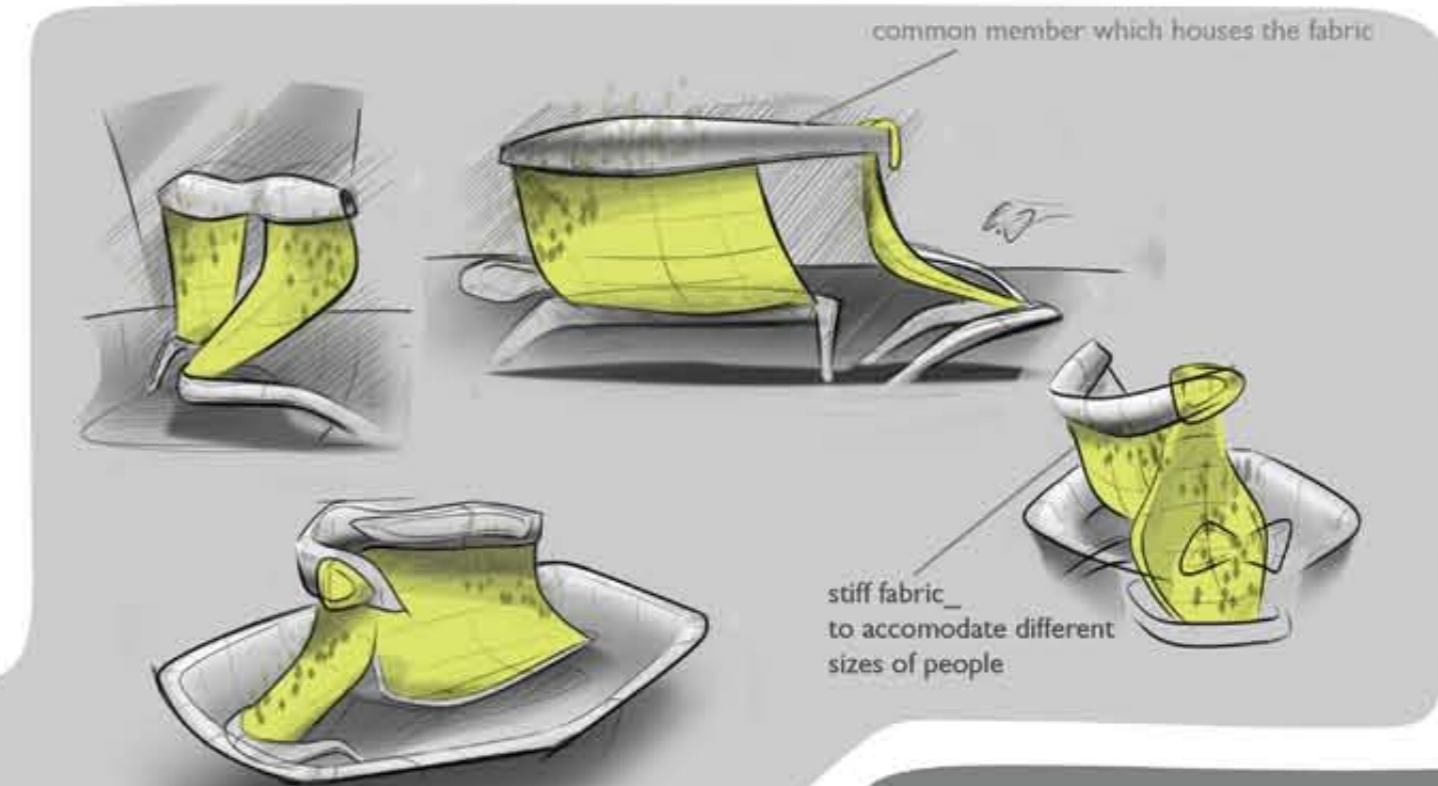
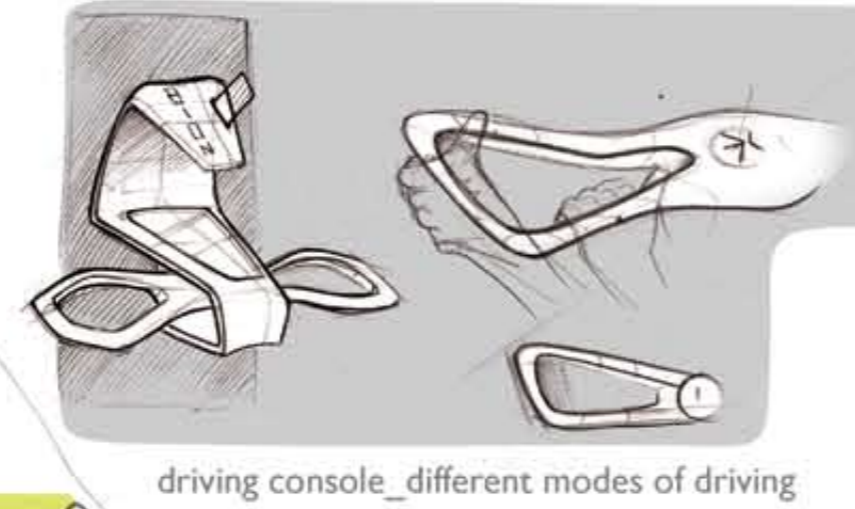
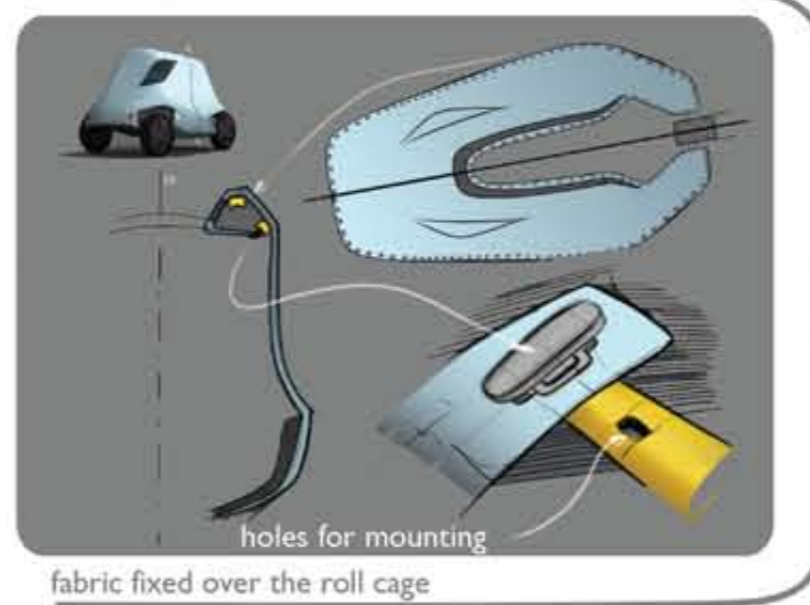
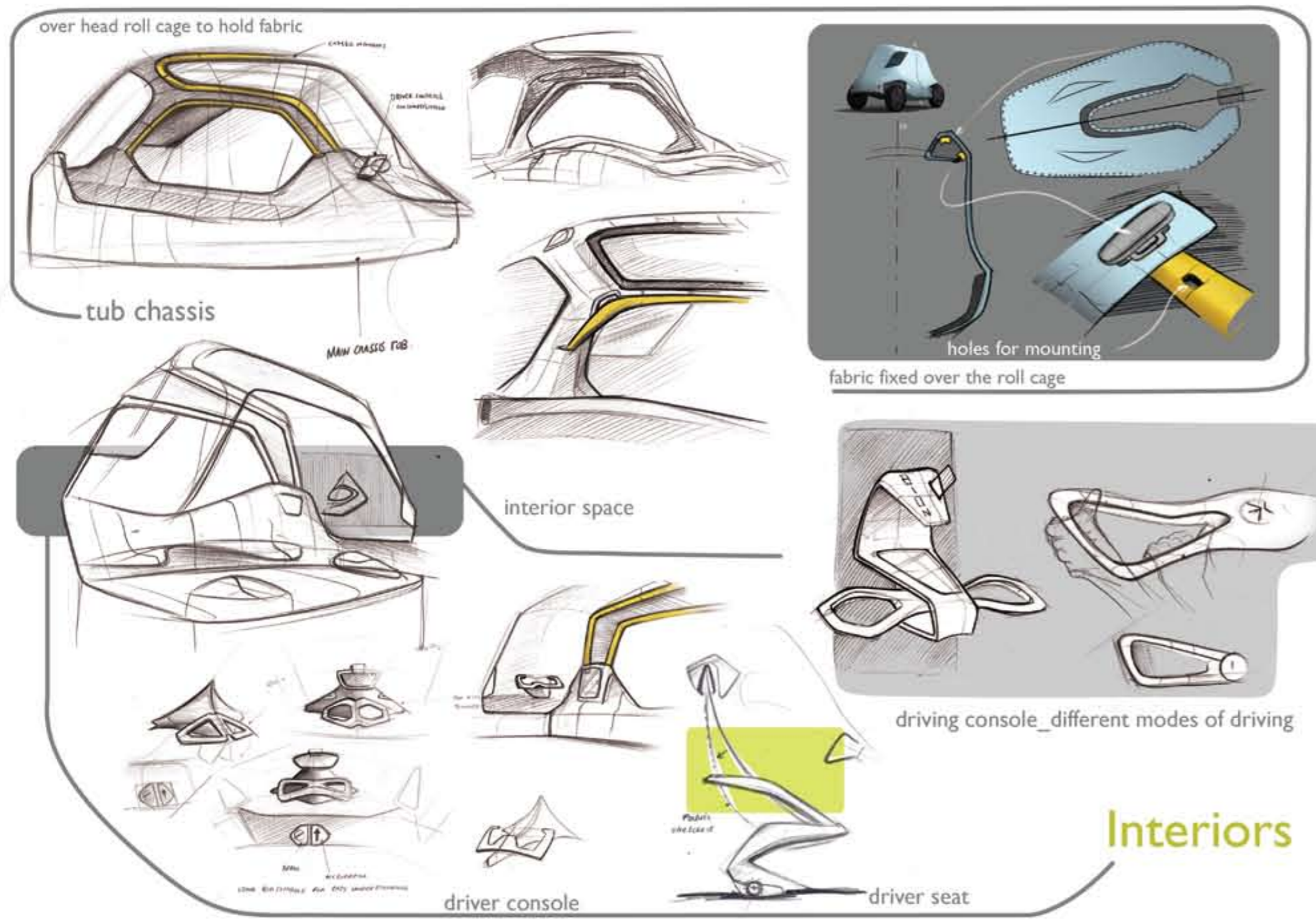

seating

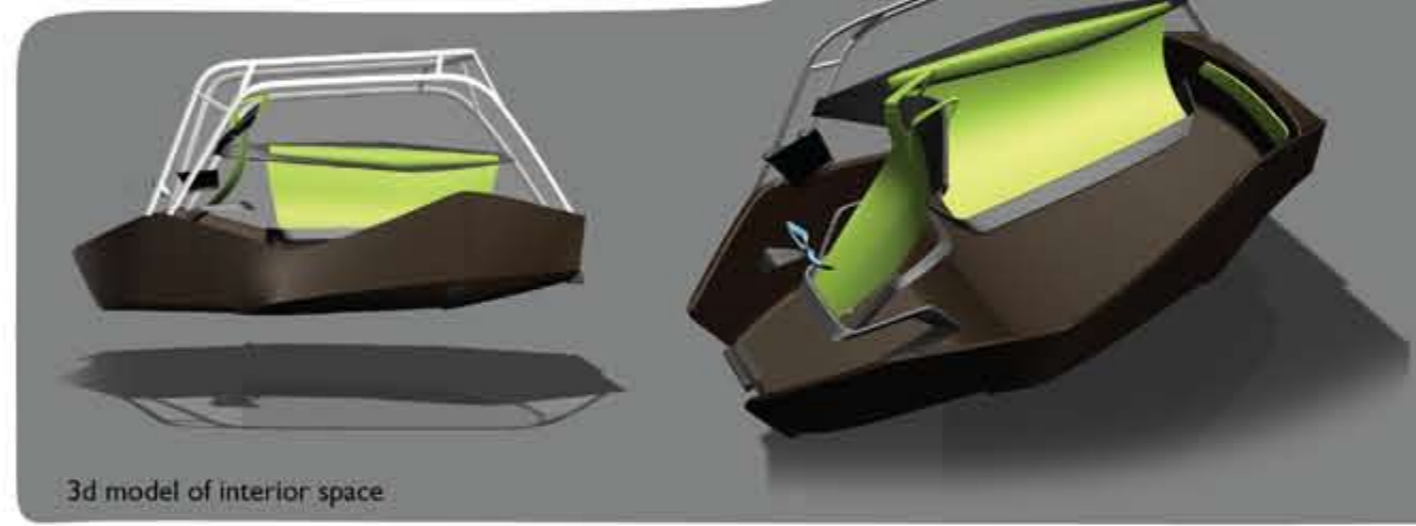

Interiors



Final 3d model



Overall Length : 3400 mm
 Height : 1850 mm
 Width : 1200 mm

This shows how the car will accommodate 4 people comfortably and still have ample space to carry personal stuff and some luggage.



just before going for the journey

scenarios



people having a comfortable chat sitting on the floor by folding of the seats



at the market

HM Ambassador

internship at ONIO Designs, Pune

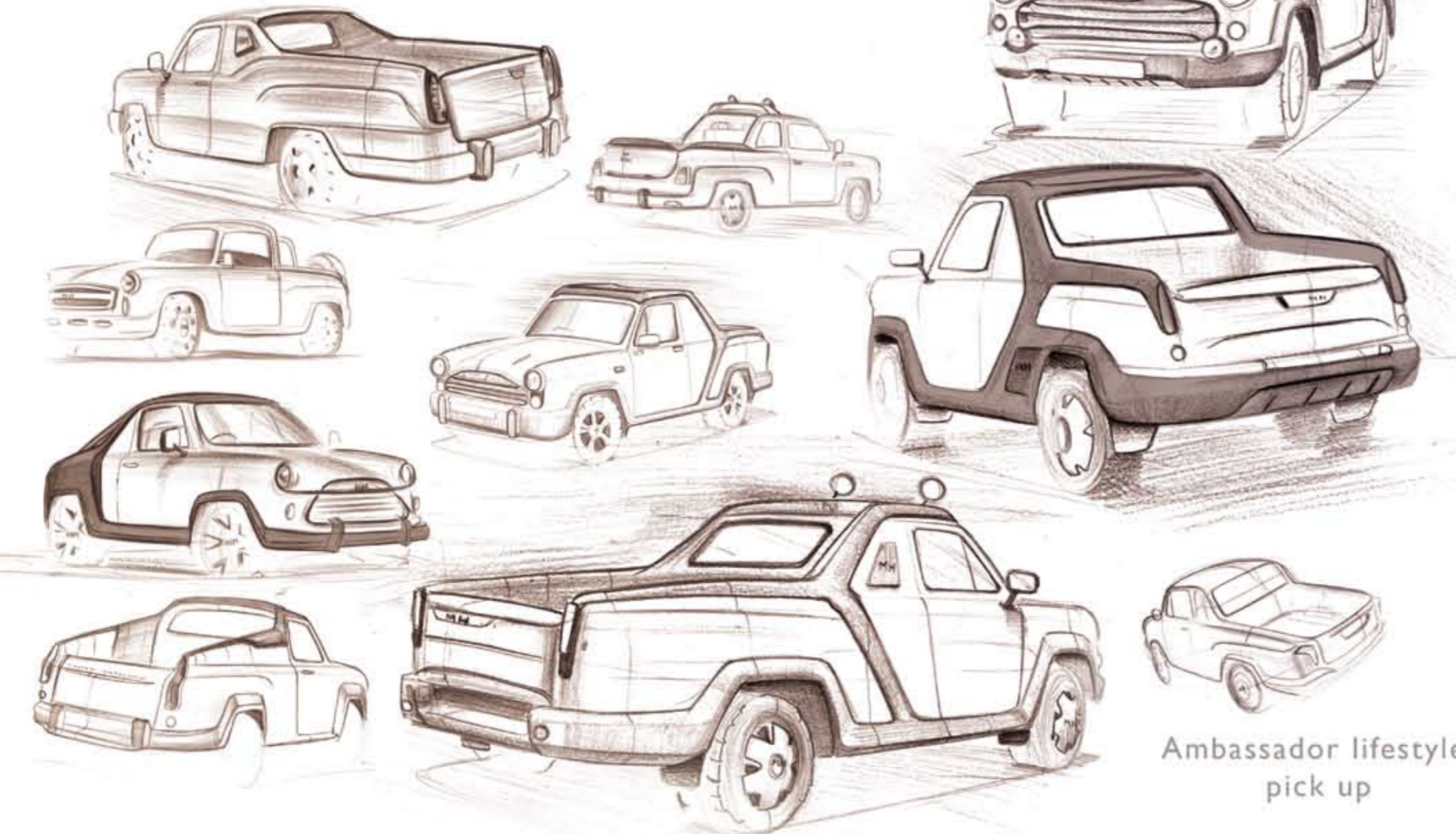

Ambassador lifestyle
pick up

Ambassador face lift

Theme : retro

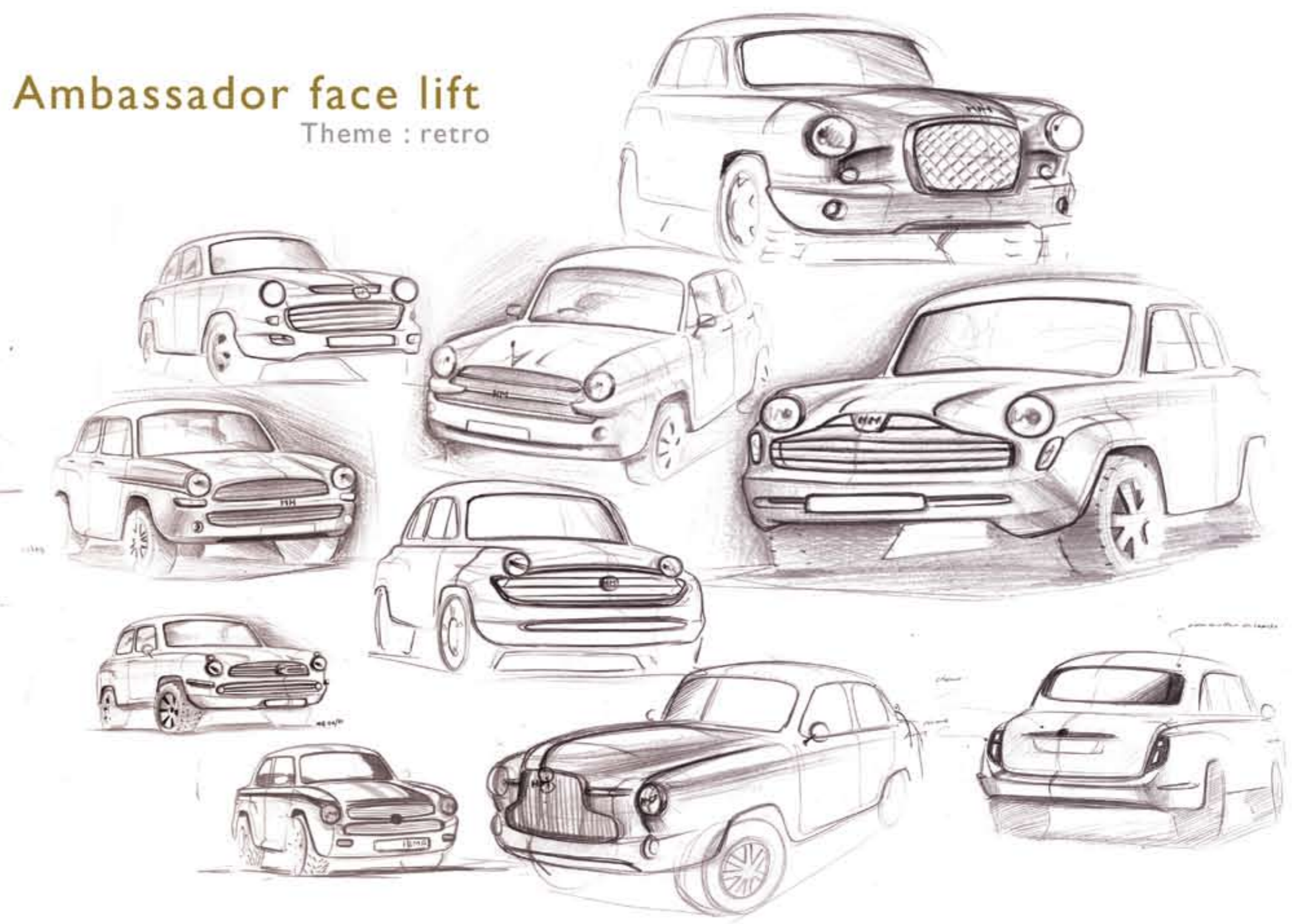

pininfarina design contest '10

Taxi for school children



FUN

FLEXIBLE

SAFE

FRESH



an electric taxi, with fabric exterior & interior

- Fabric gives more flexibility and allows kids to take any posture they want



fabric exterior

slits to allow air to pass through



front entry

colored windows

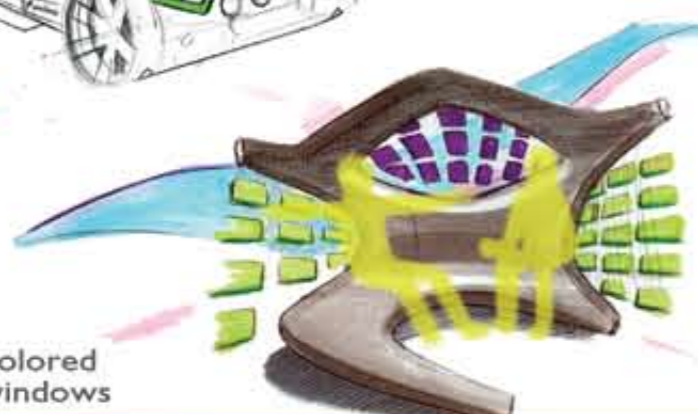

fabric woven interiors



sketch for the woven interior



scenario

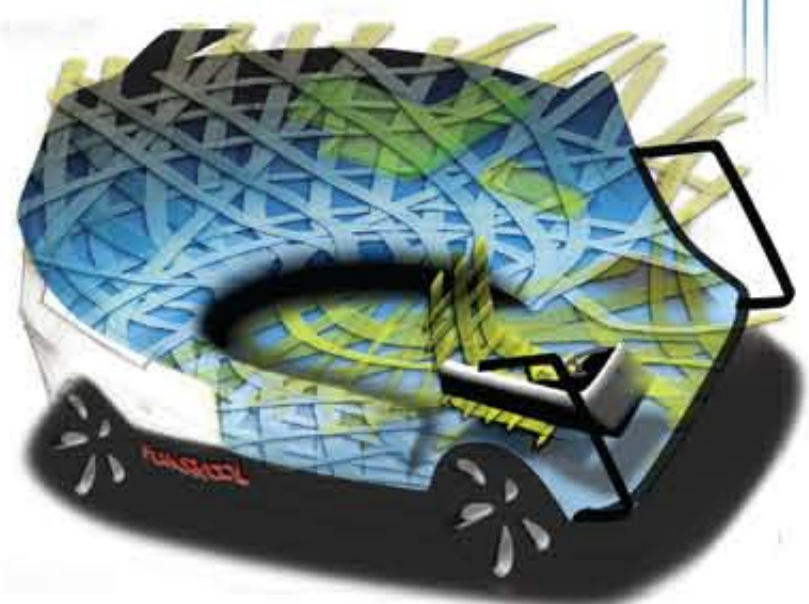



interior motives' | |
car for the digital age

kompartner

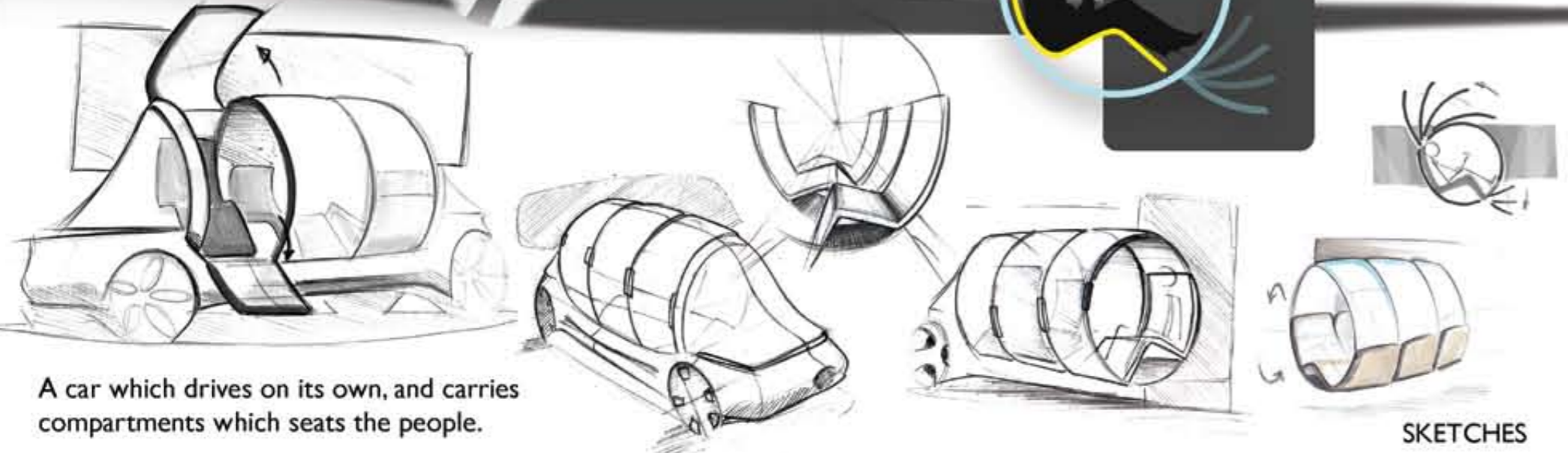
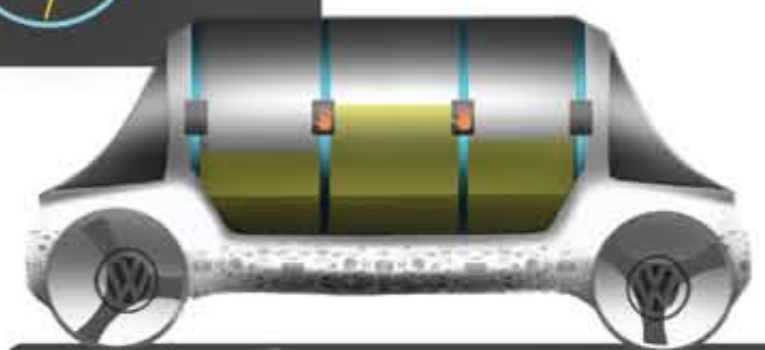
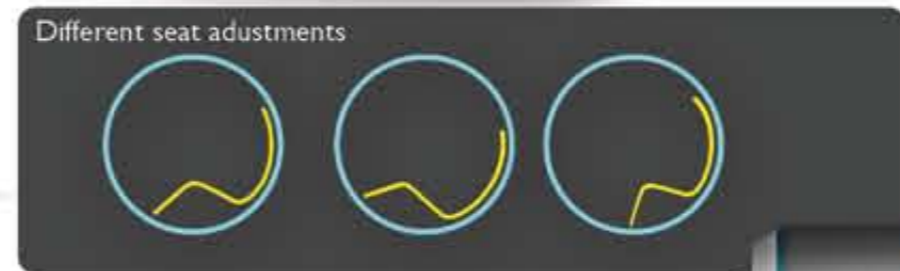
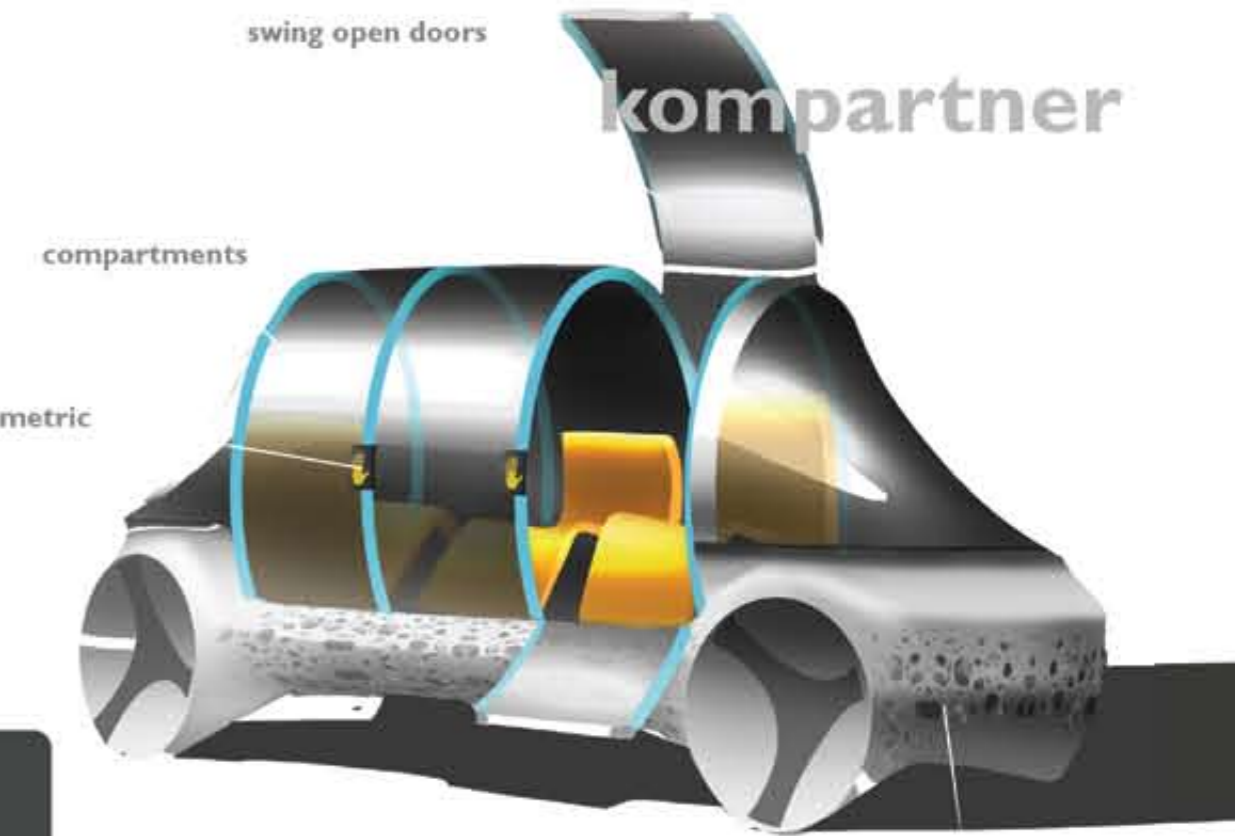
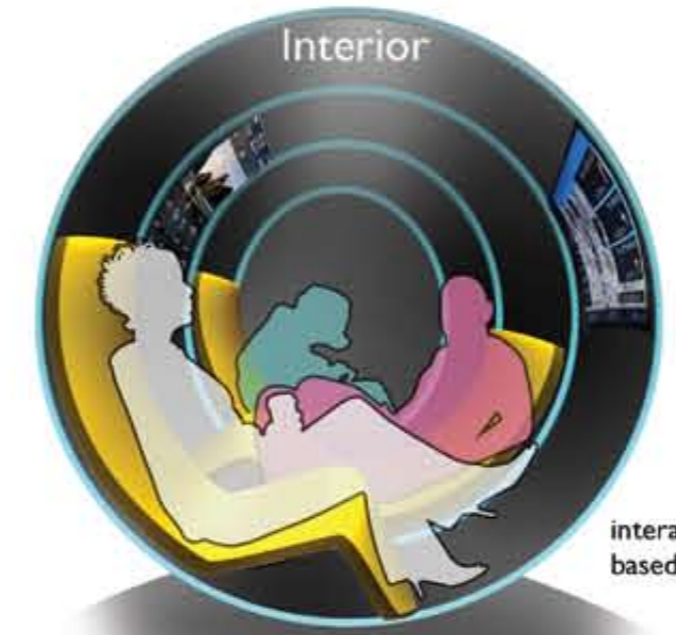
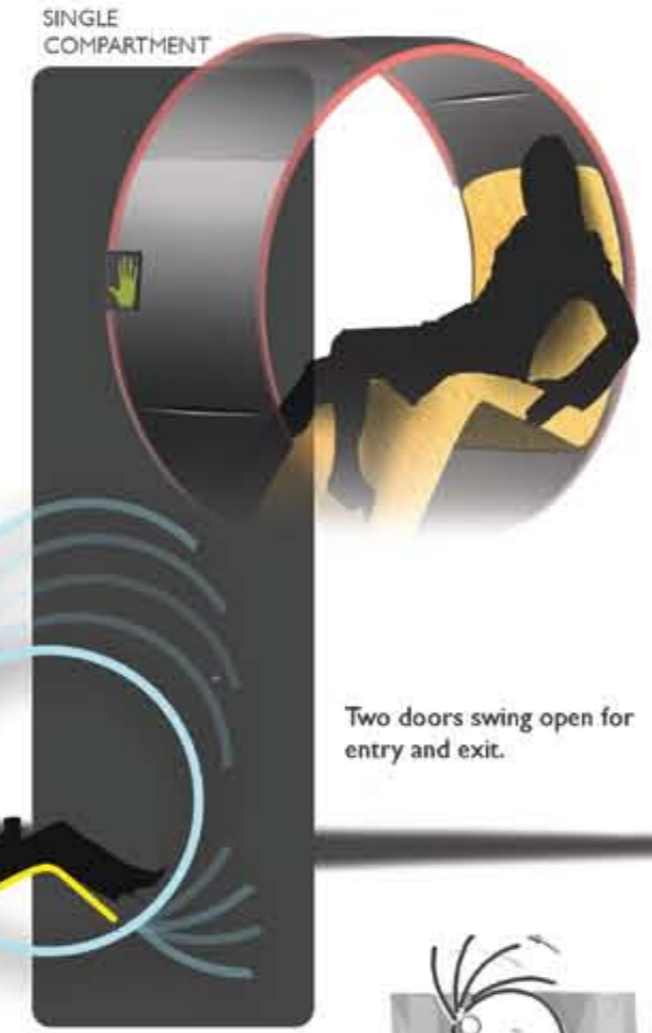
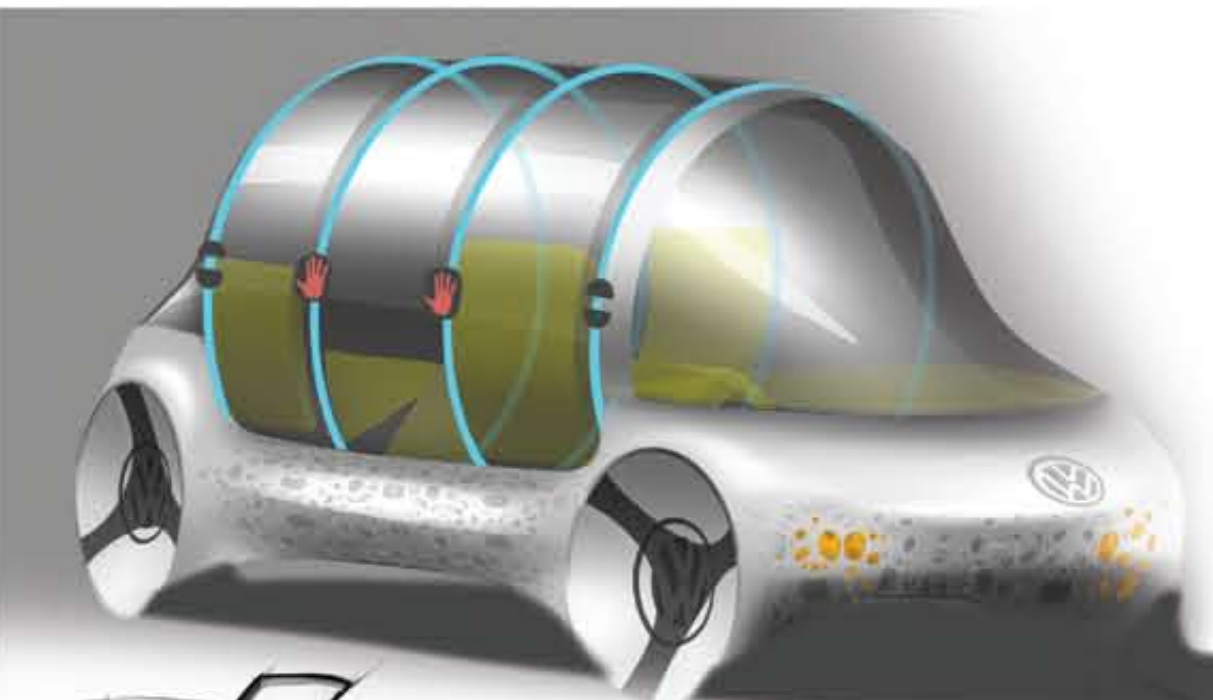

A car which drives on its own, and carries compartments which seats the people.

SKETCHES

This driver free vehicle makes people as only users. people can enjoy the ride with others as well as do their work.

QuadRover

rescue hovercraft for The Indian coast guard

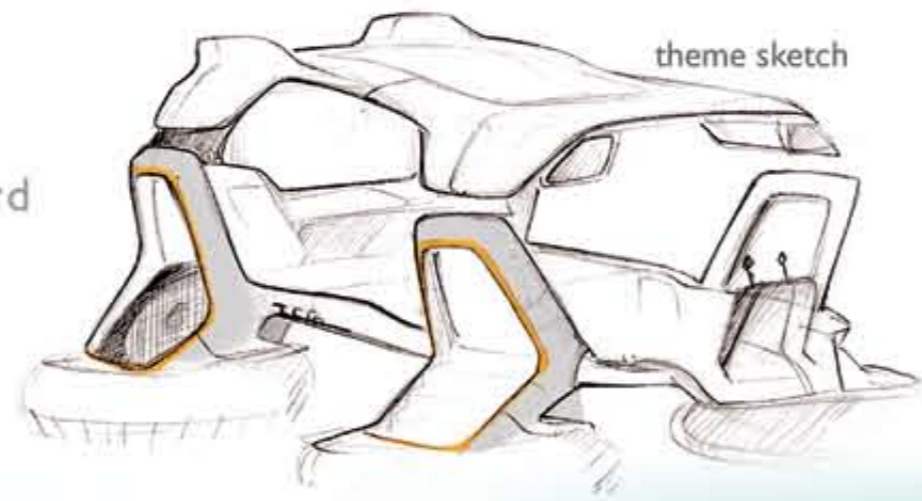

theme sketch

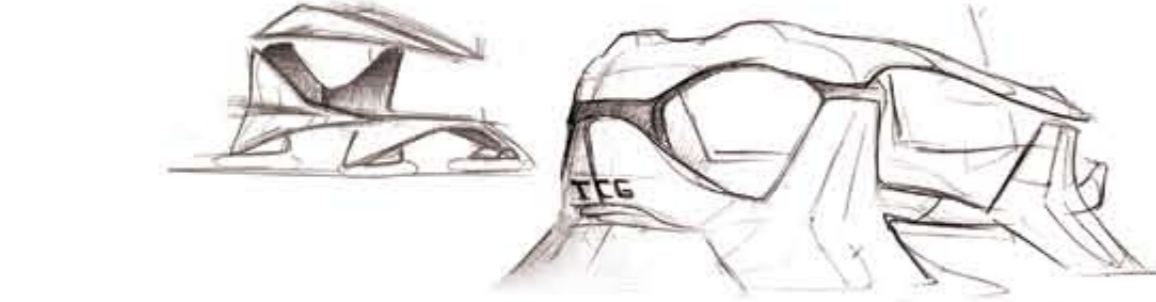

four podded hovercraft- better stability & easy maneuverability

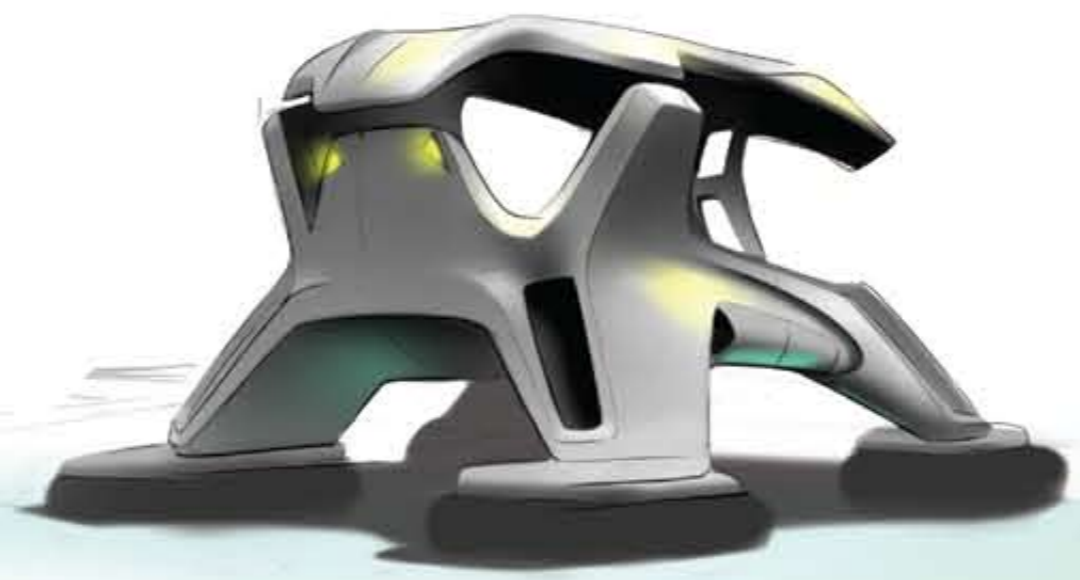

rear



front 3/4 th tip up view

explorations

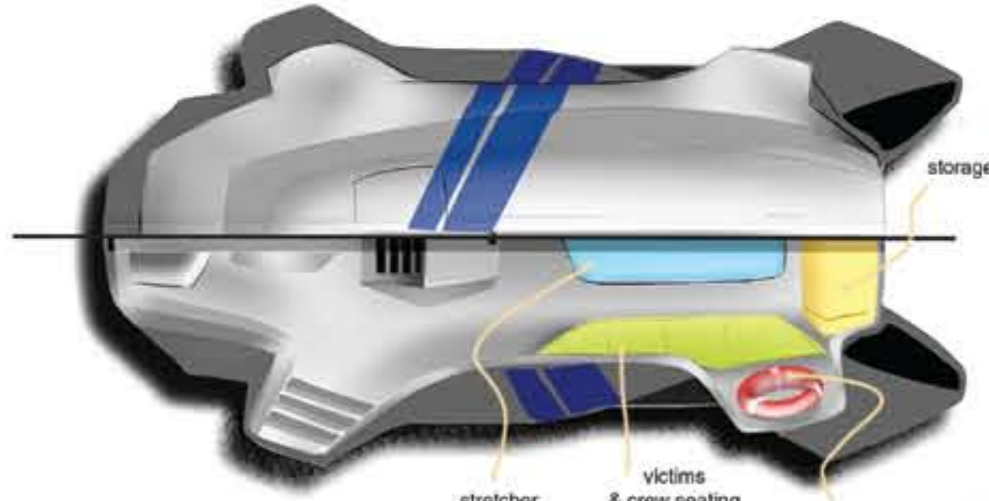

top view cut section- interiors

- storage
- stretcher
- victims & crew seating
- safety equipment



clay model
scale- 1:18

QuadRover

rescue hovercraft for The Indian coast guard



De Lorean

rebirth

Delta

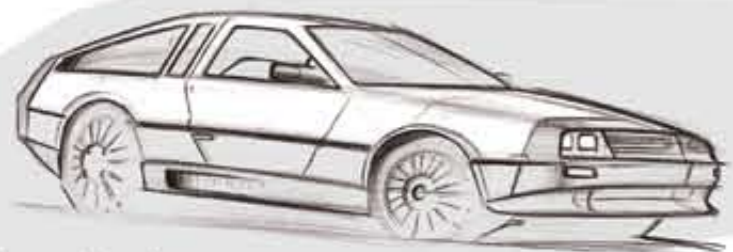

the original

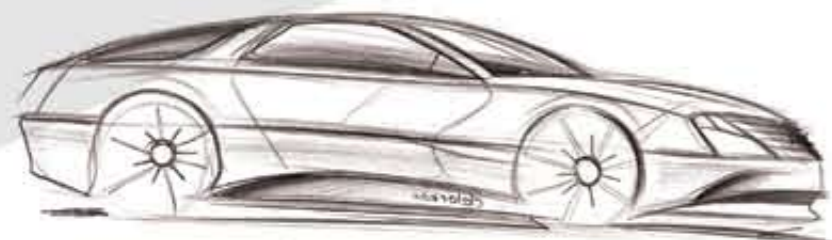

the original



makeovers-
rebirth of legendary cars

sketches

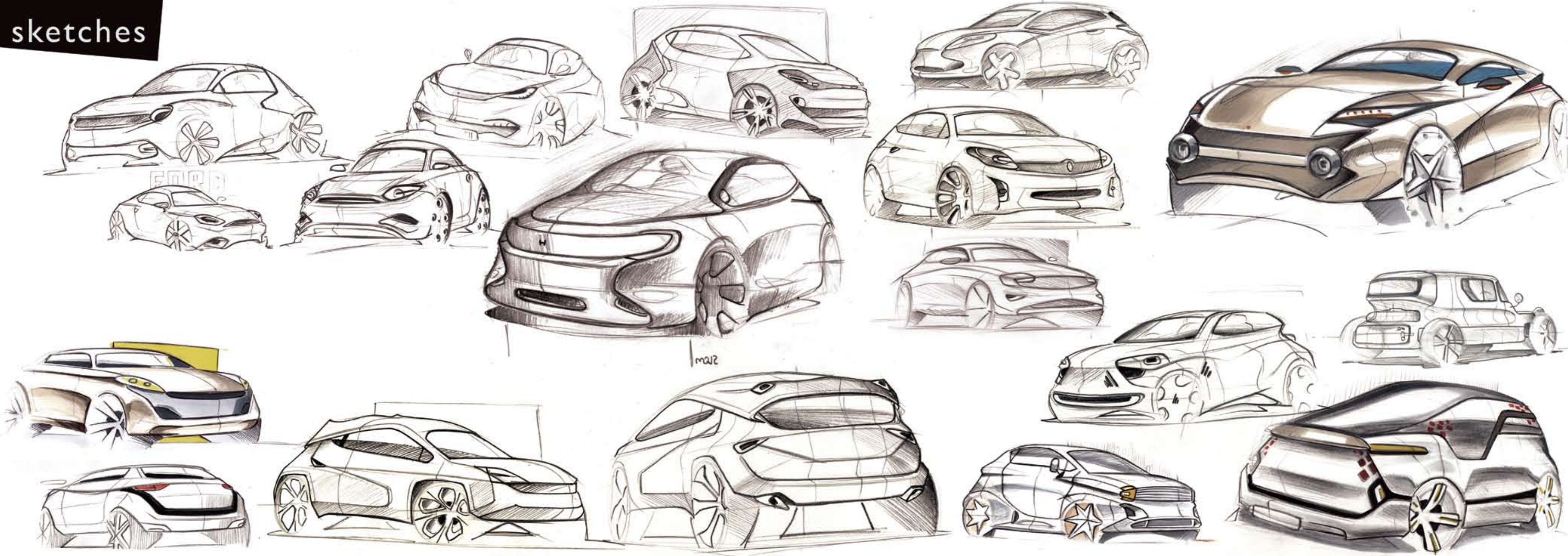

sketches

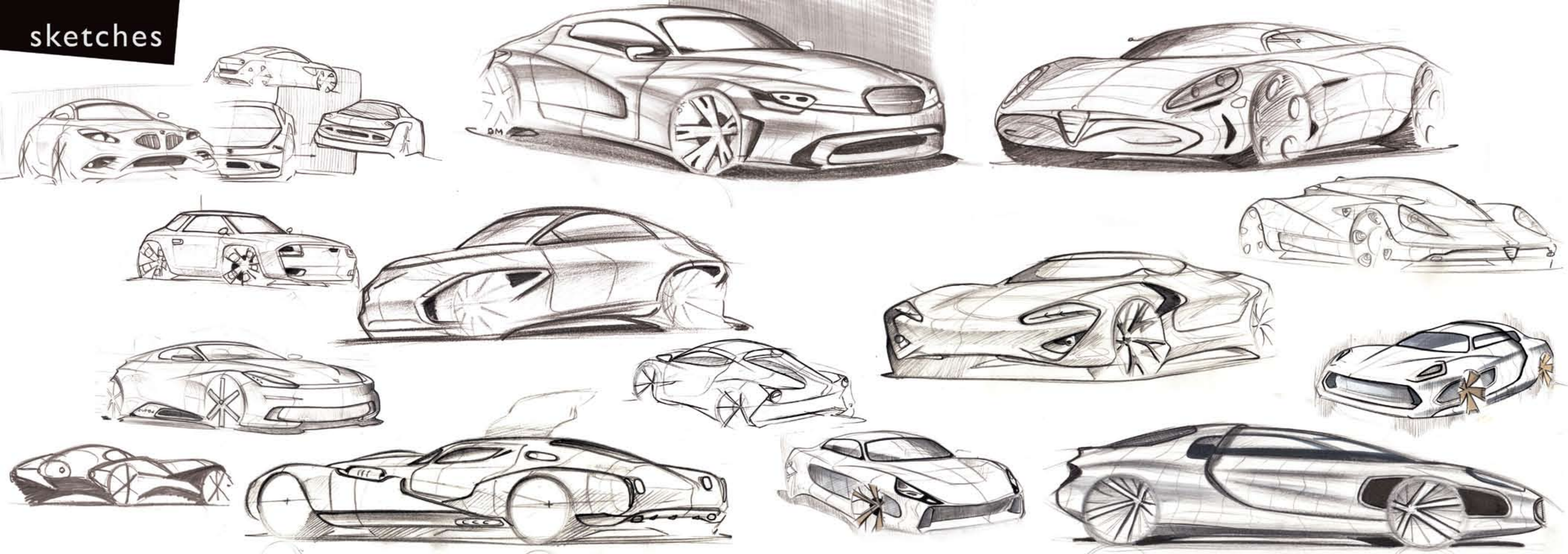

sketches
interiors

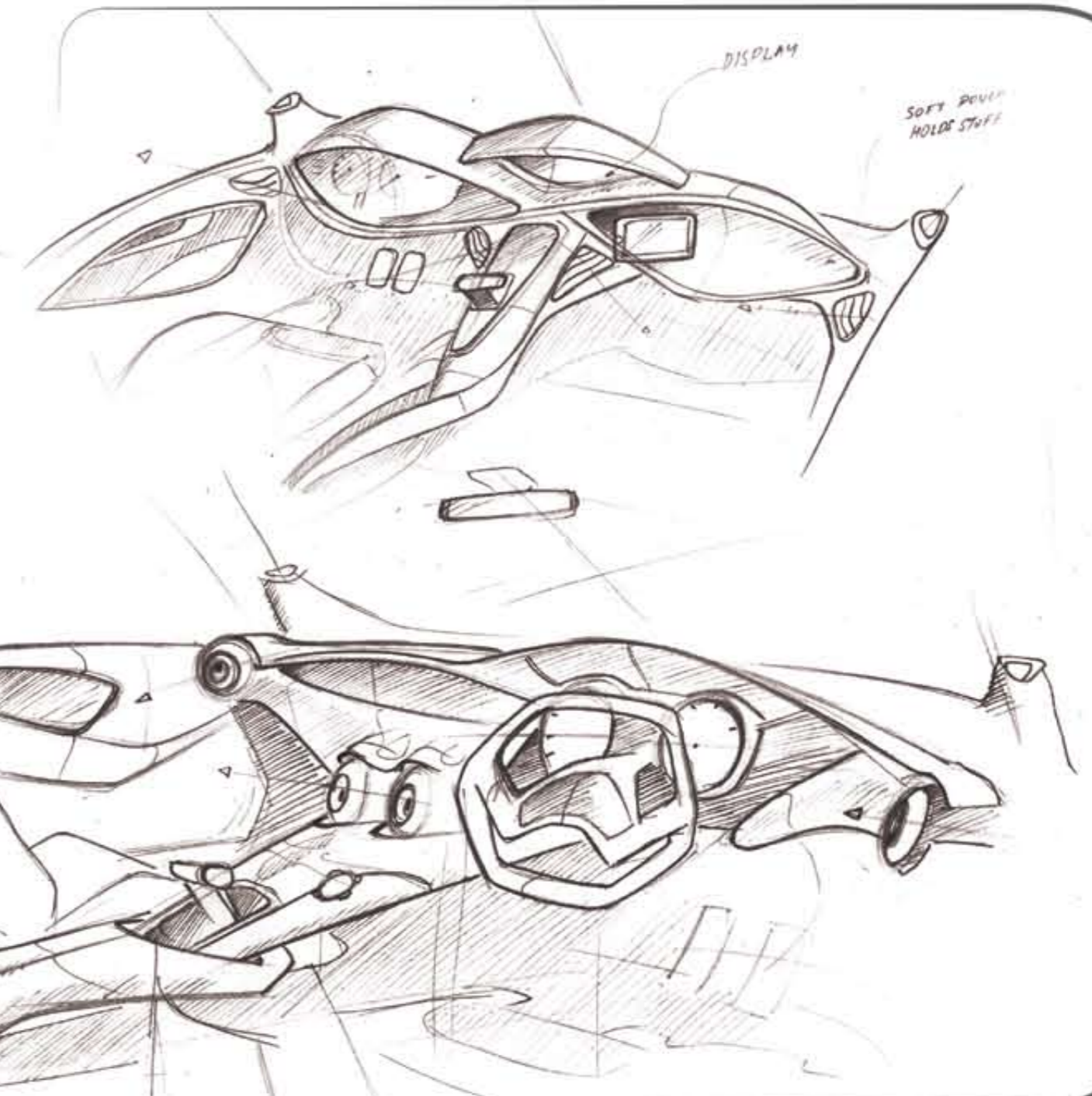
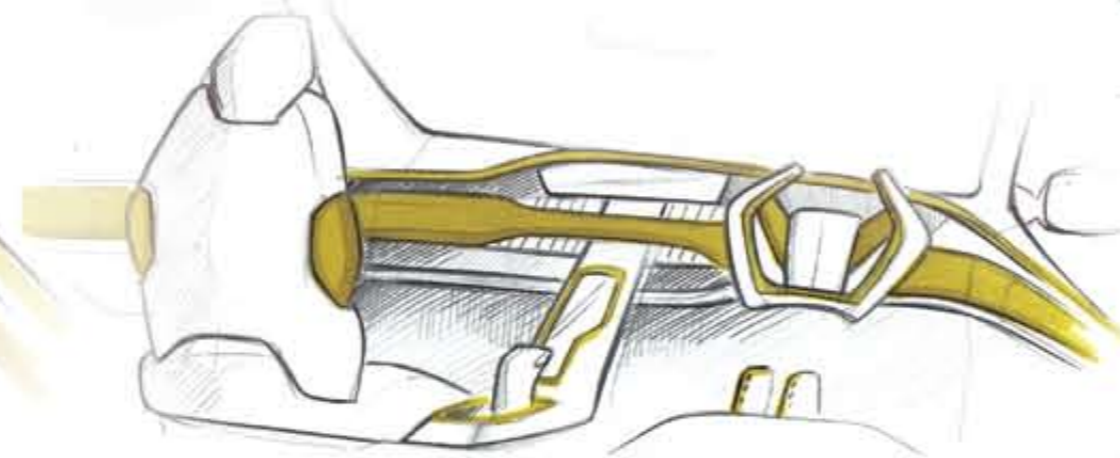
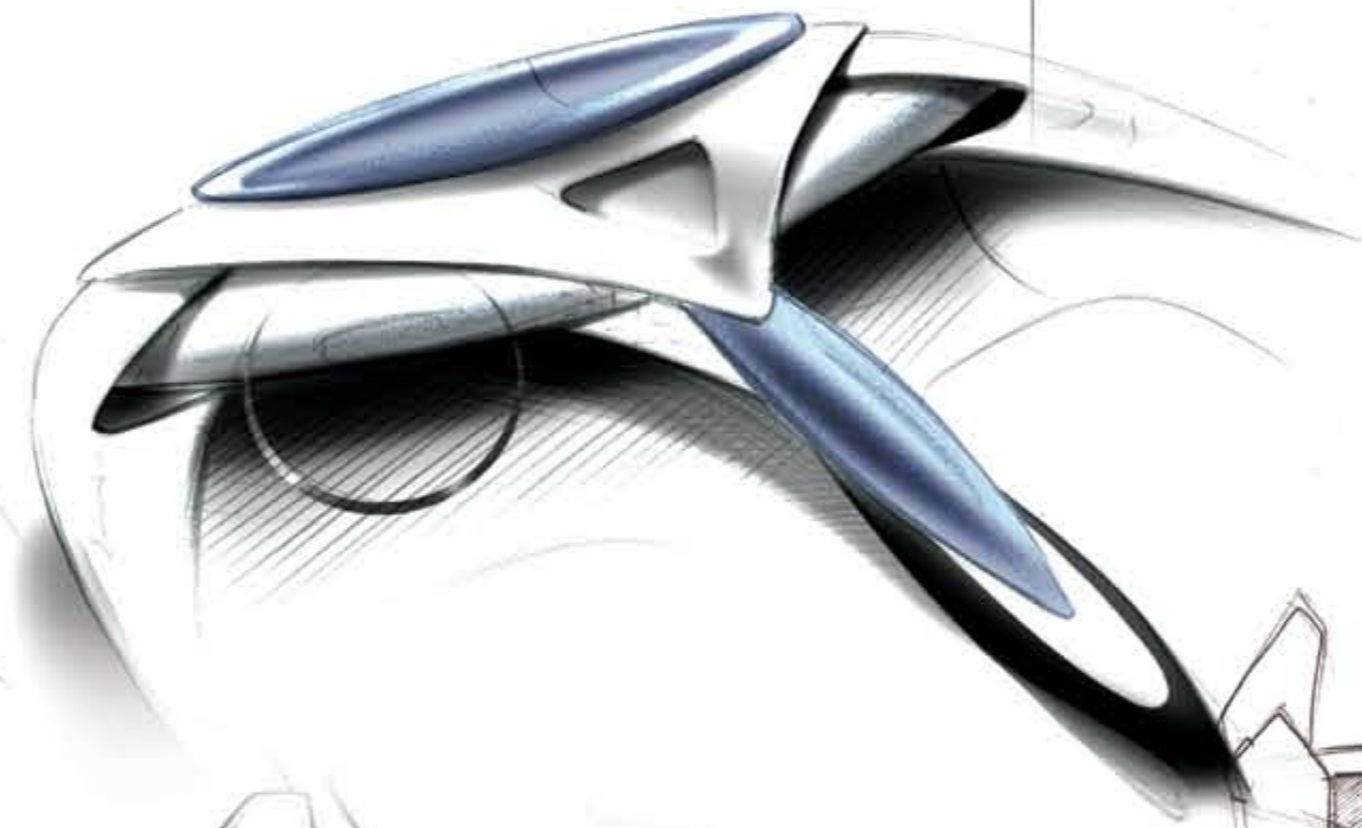
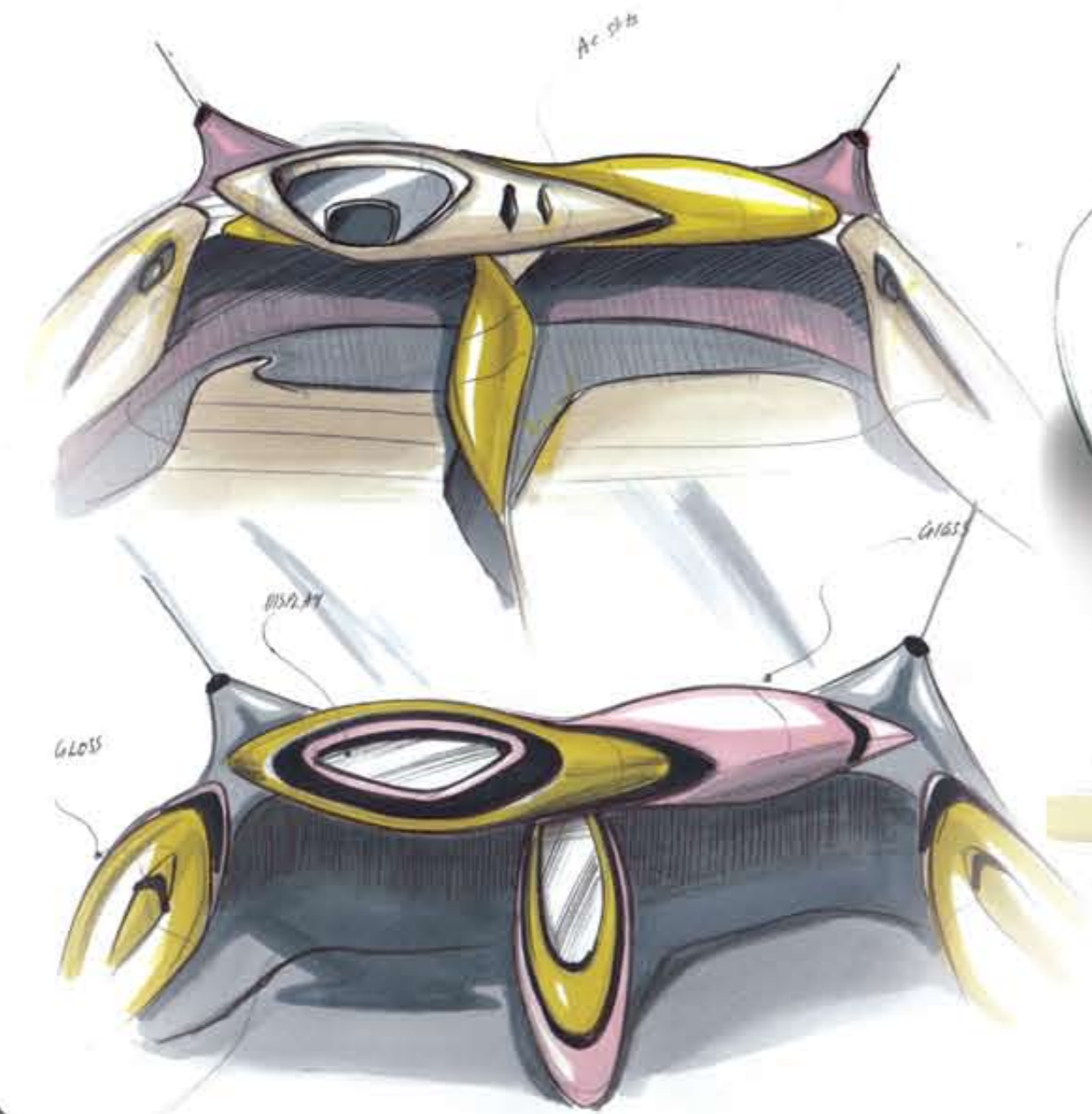

renders

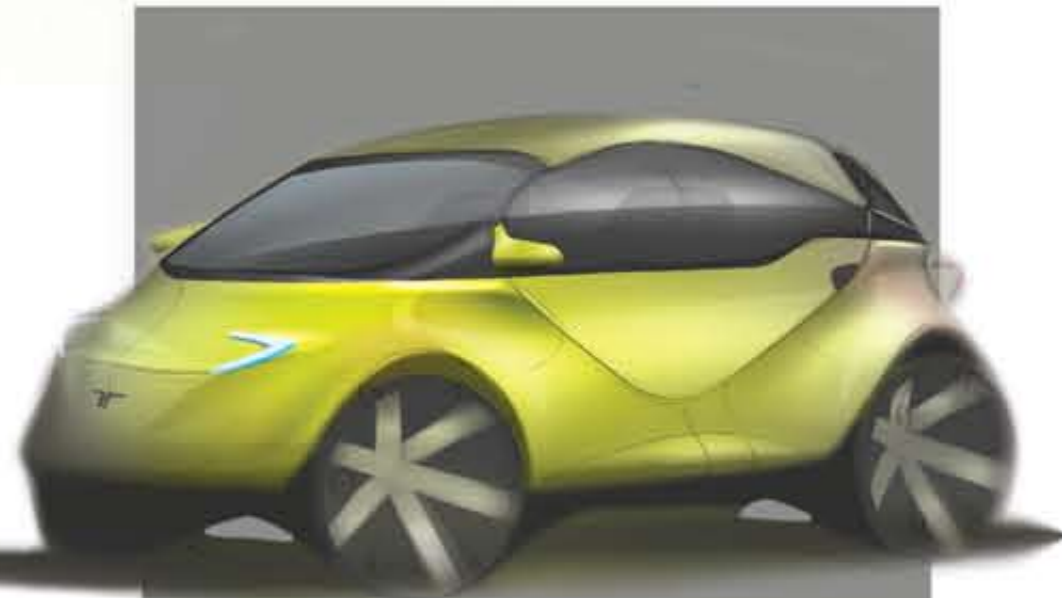
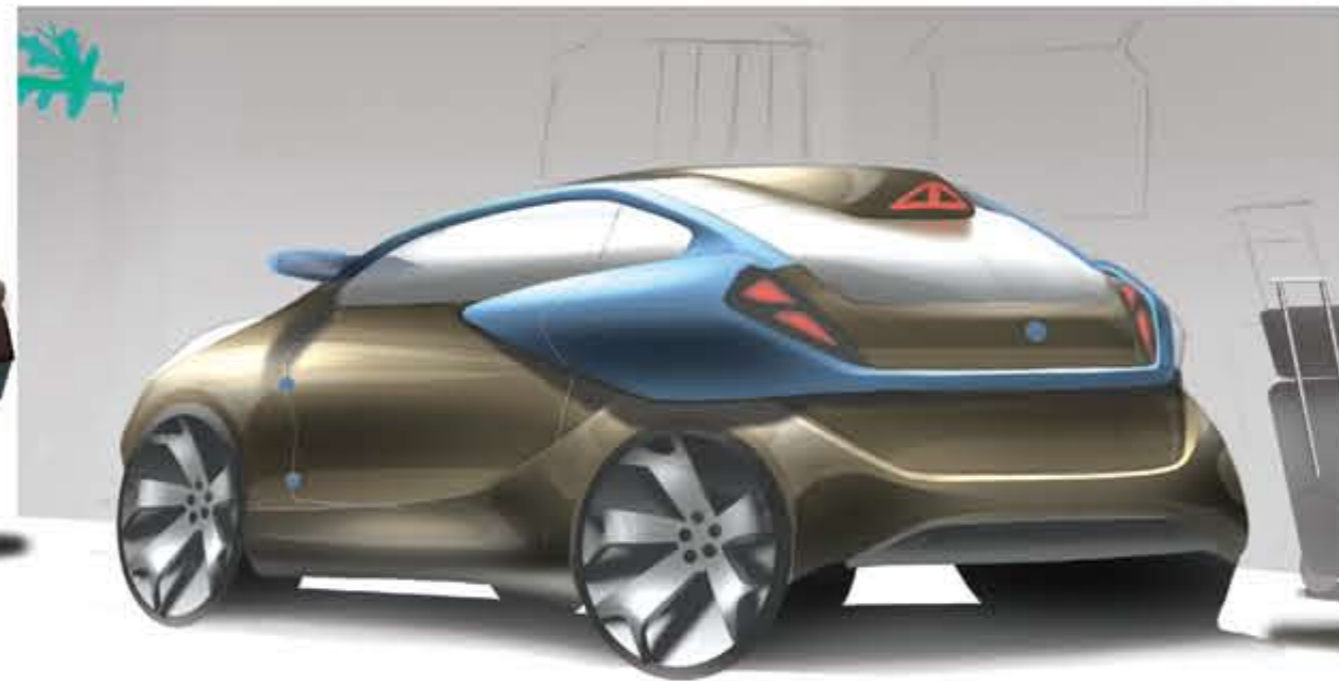
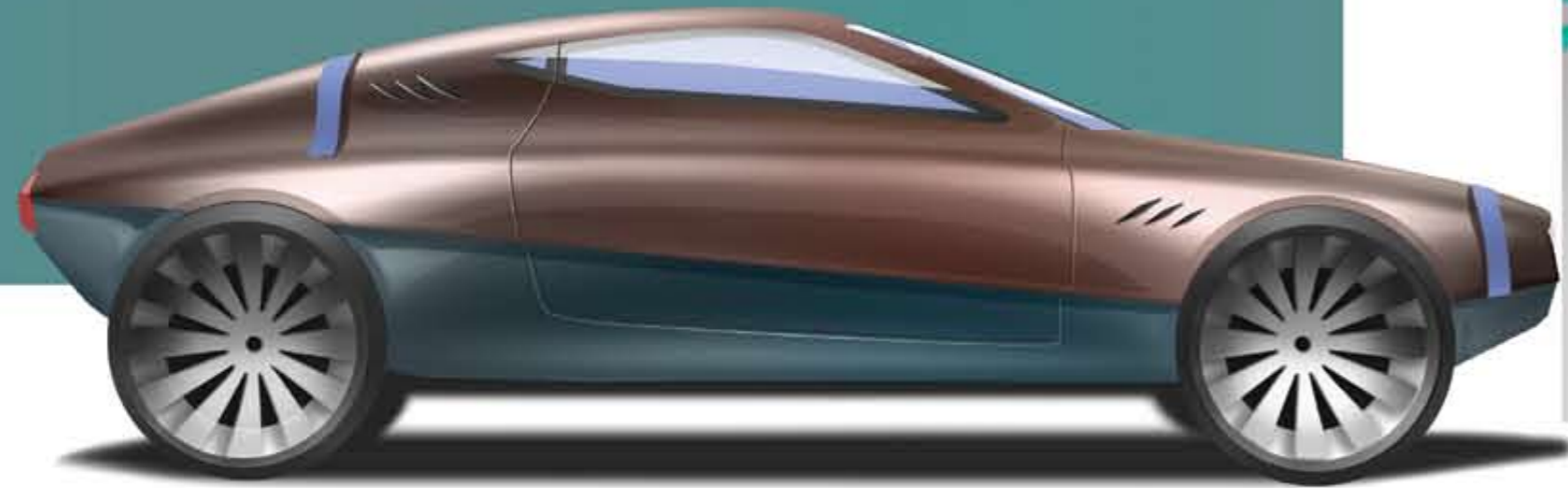
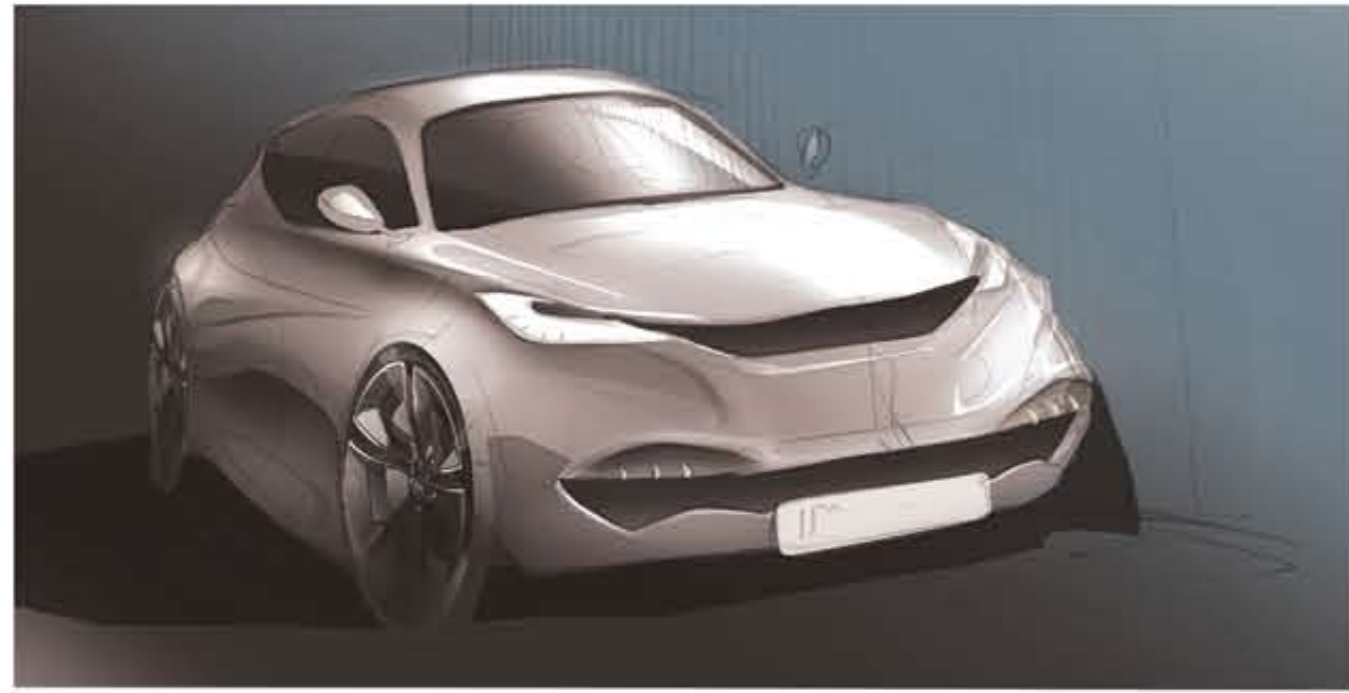

renders

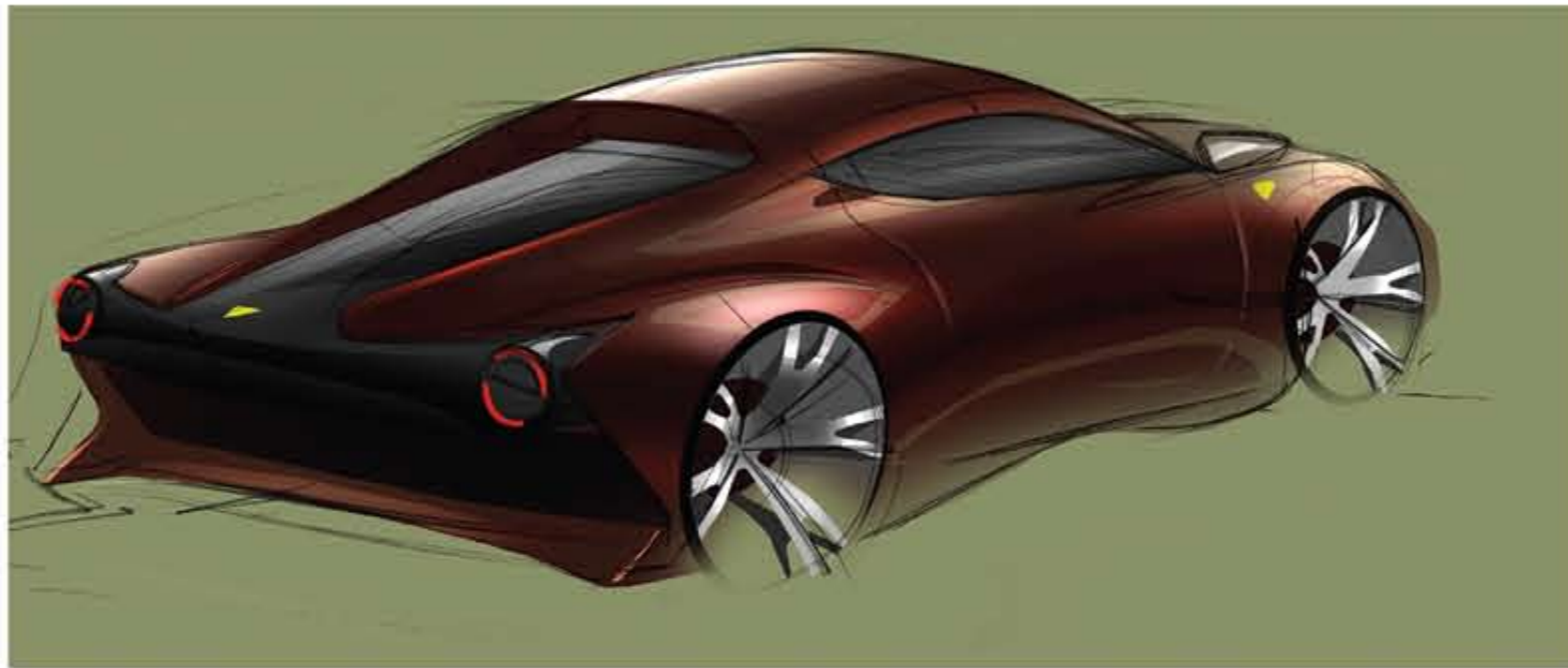
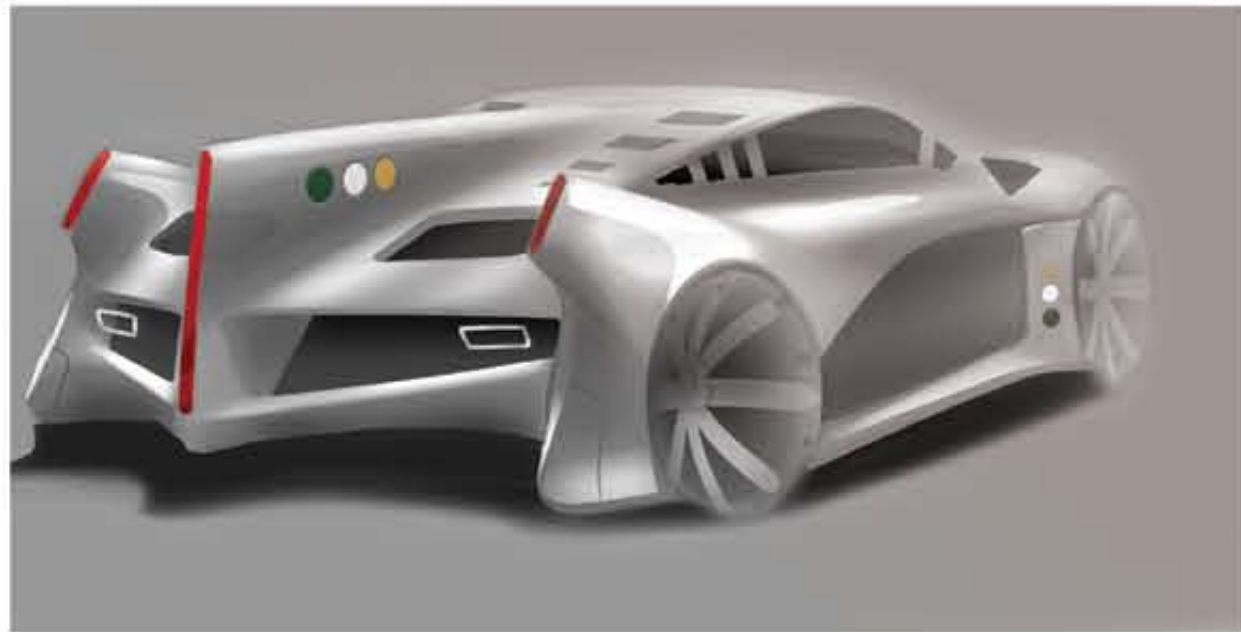
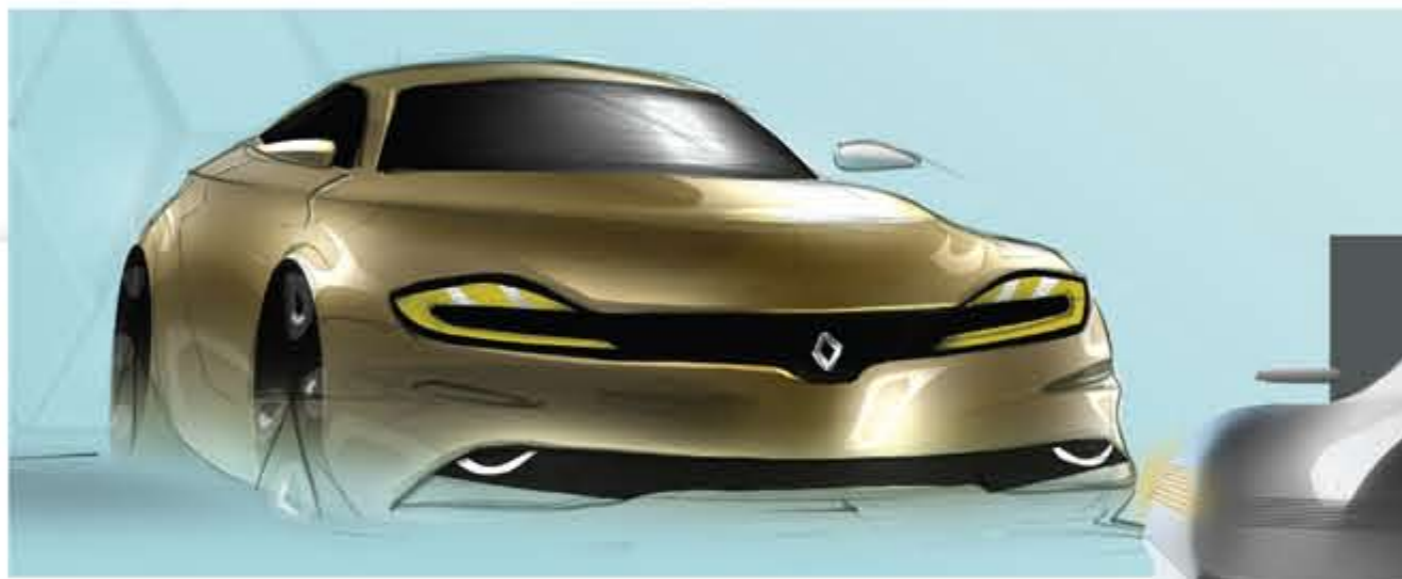

Mercedes
sports coupe

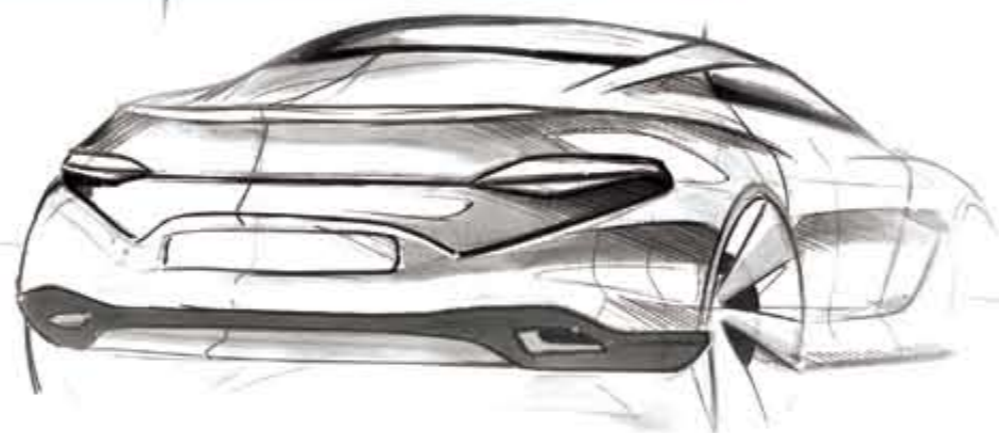

Ferrari





THANK YOU

mushtaqmq@gmail.com

+91 97865 69358

mushtaqanis.blogspot.com